

Multifunction Digital Adapter-Aircraft

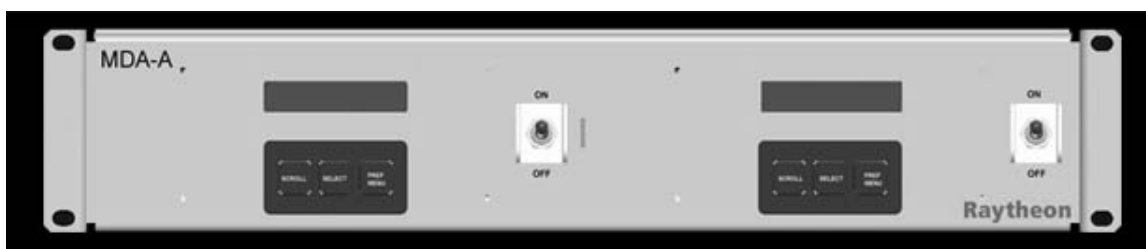

User's Manual
Doc. 2AA-02391-0100

ABOUT THE COMPANY

Telecore, Inc. is a telecommunications research and development company. The company's unique vision supports both fundamental research and commercialization activities within one organization, funded by both private resources and programs. The company will achieve its long-term mission -- to be one of the world's telecommunications leaders -- by building on its track record of outstanding technical successes.

Telecore's products will produce a fundamental change in communications, in much the same way that the integrated circuit revolutionized data processing. Telecore's blend of world-class researchers and product developers place it at the forefront of the telecommunications industry.

Telecore, Inc.
1800 North Glenville Dr.
Suite 116
Richardson, TX 75081-1953

COPYRIGHT AND RIGHTS

DOCUMENT COPYRIGHT

No part of this document may be reproduced in any form or by any means without prior written authorization from Telecore.

While all reasonable effort has been made to ensure the accuracy of this document, Telecore assumes no liability resulting from errors in/omissions from this document or use of information in this document. The information in this document has been carefully reviewed and is believed to be reliable and to conform to the specifications provided by the contracting entity. However, no responsibility is assumed for inaccuracies.

Copyright © 2009 Telecore

ALL RIGHTS RESERVED

The Government's rights to use, modify, reproduce, release, perform, display, or disclose this technical data are restricted by clause(s) in the contract. Any reproduction of technical data or portions thereof marked with this legend must also reproduce the markings.

SOFTWARE COPYRIGHT

The equipment described in this manual includes computer programs that are stored in semiconductor memories or other media. The software is owned or licensed by Telecore, Inc. and is protected by copyright, trade secret, patent, or other intellectual property laws. Accordingly, the software may not be copied or reproduced in any manner without the express written permission of Telecore.

Additionally, copyright protection claimed includes all forms of matters of copyrightable materials and information allowed by statutory or judicial law or hereinafter granted, including without limitation, material generated from the software programs.

Raytheon[®] is a registered trademark of Raytheon Company. All other product names mentioned in this document may be the trademarks or registered trademarks of their respective companies.

DISCLAIMER

Note: This document makes use of graphics and images depicting the information and operation of the MDA-A and, as such, the information is to be taken as examples only.

Document Change Revision Log

DOCUMENT REVISION	DATE	DESCRIPTION OF CHANGE	SECTIONS AFFECTED
2AA-02391-0000	06/03/09	New document	All
2AA-02391-0100	16/10/09	Incorporate changes made to MDA User's Guide	All

THIS PAGE INTENTIONALLY LEFT BLANK.

Table Of Contents

1	Initial Configuration	2
2	Product Description	2
3	Specifications	3
3.1	Physical Characteristics	3
3.1.1	MDA-A Front Panel	4
3.1.2	MDA-A Rear Panel	4
3.2	Security and Privacy	5
4	Functional Description	6
4.1	MDA Interface Connectivity	7
4.2	DTA/DPA Supported Operational Modes (Bravo).....	9
4.2.1	Bravo One.....	9
4.2.2	Bravo Two.....	9
4.3	Four Phone Mode	10
4.4	Four Trunk Mode	10
4.5	MIL-188-114 Data Capabilities.....	11
4.5.1	56/64 kbps	11
4.5.2	128 kbps.....	11
4.5.3	256 kbps.....	11
4.5.4	512 kbps.....	11
4.6	Fiber Optic Data Capabilities	11
4.7	Black Digital Subscriber/Trunk Mode.....	12
4.8	Simple Network Management Protocol (SNMP)	13
5	Configuration.....	14
5.1	Status Display	14
5.2	User Interface Menu Map.....	15
5.3	Statistic Information	16
5.3.1	Statistic Display Menu.....	16
5.3.2	Statistic Information Displays	16
5.4	System Configuration	19
5.4.1	System Configuration Menu.....	19
5.4.2	System Configuration Display.....	19
5.5	System Parameter Modification Displays.....	27
5.5.1	System Parameter Modification Menu	27
5.5.2	System Parameter Modification Displays.....	27
5.5.3	Modifying the MDA Ethernet Addresses	33
5.6	Remote Status Information	33
5.6.1	Remote MDA UDLT Remote Status Display	33
5.6.2	Remote MDA BSP Part Number and Revision Display.....	34
5.6.3	Remote MDA Application Part Number and Revision Display	34
5.6.4	Remote MDA Multilink PPP Application Part Number and Revision Display.....	34
5.6.5	Remote MDA DSP Part Number and Revision Display.....	34
5.6.6	Remote MDA FPGA Part Number Display.....	34
5.6.7	Remote MDA CPLD Part Number Display.....	35
5.6.8	Remote MDA Internal Temperature Display	35
5.6.9	Remote MDA Serial Number Display	35
5.6.10	Remote MDA 100 Mbit Ethernet Address Display	35
5.6.11	Remote MDA 10 Mbit Ethernet Address Display	35
5.6.12	Remote MDA Operating Mode	36
5.6.13	Remote MDA MIL188 ReSync.....	36
5.6.14	Remote MDA MIL188 ReCenter	36
5.7	Detailed Menu	36
6	MDA Crypto Resync Capability	39
6.1	“Single Ended” Resync	40

6.2	“Differential” Resync	40
6.3	Crypto Resync/Link Configuration Capability	41
6.4	Crypto Alarm for Black Digital Mode.....	41
6.5	Special Configuration Instructions for MDA Black Digital Parameters.....	42
7	SNMP Trapping.....	44
8	Software Upgrade Instructions	44
8.1	Obtaining Files for Upgrade	45
8.2	Determining the MDA IP address and the BSP Version	45
8.3	MDA BSP.....	46
8.4	MDA Application/DSP/MLPPP Software and FPGA Firmware	47
8.4.1	Special Configuration Instructions for MDA Application Software Upgrade.....	48
9	Connector Signals.....	49
9.1	J1 and J2	49
9.2	J3, J8 - RS-232 Async and Synchronous Interface, Electrical T1/E1,.....	49
9.3	J4, J5, J9 and J10 - UDLT and Ethernet Interfaces	50
9.4	Transmit/Receive Fiber Optic Interface	52
10	Terms/Definitions.....	53
11	Warranty Terms and Conditions.....	54
11.1	Shipping Return Address.....	54

Table of Figures

Figure 3-1:	MDA-A Physical Dimensions (in inches)	3
Figure 3-2:	MDA-A Front Panel	4
Figure 3-3:	MDA-A Rear Panel	4
Figure 4-1:	Phone Interface (Remote) MDA Configuration.....	7
Figure 4-2:	Fiber Optic Phone Interface (Remote) MDA Configuration	7
Figure 4-3:	Switch Interface (Local) MDA-A Configuration.....	8
Figure 4-4:	Fiber Optic Switch Interface (Local) MDA-A Configuration	8
Figure 4-5:	SNMP Connection to MDA.....	8
Figure 4-6:	System level application of the MDA, BRAVO I MODE.....	9
Figure 4-7:	MDA Four Trunk Mode Configuration	10
Figure 4-8:	Black Digital Trunk Configuration.....	12
Figure 4-9:	Black Digital Subscriber Configuration.....	13
Figure 5-1:	Status Display Examples	14
Figure 5-2:	MDA User Menus.....	15
Figure 5-3:	Statistic Display Menu.....	16
Figure 5-4:	MDA UDLT Status Display (port up or down).....	16
Figure 5-5:	MDA UDLT Valid Data Ports.....	16
Figure 5-6:	MDA UDLT Long Haul Communications	17
Figure 5-7:	MDA Board Support Package Part Number and Revision Display.....	17
Figure 5-8:	MDA Application Code Segment Part Number and Revision Display	17
Figure 5-9:	MDA Application Code Segment Part Number and Revision Display	17
Figure 5-10:	MDA Digital Signal Processor Part Number and Revision Display.....	17
Figure 5-11:	MDA FPGA Part Number Display	18
Figure 5-12:	MDA CPLD Part Number Display	18
Figure 5-13:	Internal Temperature Display	18
Figure 5-14:	Serial Number Display	18
Figure 5-15:	100 Mbit Ethernet Address Display.....	18
Figure 5-16:	10 Mbit Ethernet Address Display.....	19
Figure 5-17:	Product Manufacturer Information	19
Figure 5-18:	System Configuration Menu	19
Figure 5-19:	Bravo/56K/Phone System Configuration Display	21
Figure 5-20:	Bravo/56K/Switch System Configuration Display	21
Figure 5-21:	Bravo/64K/Phone System Configuration Display	21
Figure 5-22:	Bravo/64K/Switch System Configuration Display	21

Figure 5-23: 4UDLT/56K/Phone System Configuration Display	22
Figure 5-24: 4UDLT/56K/Switch System Configuration Display	22
Figure 5-25: 4UDLT/64K/Phone System Configuration Display	22
Figure 5-26: 4UDLT/64K/Switch System Configuration Display	22
Figure 5-27: 4UDLT/128K/Phone System Configuration Display	22
Figure 5-28: 4UDLT/128K/Switch System Configuration Display	22
Figure 5-29: 4UDLT/256K/Phone System Configuration Display	23
Figure 5-30: 4UDLT/256K/Switch System Configuration Display	23
Figure 5-31: 4UDLT/512K/Phone System Configuration Display	23
Figure 5-32: 4UDLT/512K/Switch System Configuration Display	23
Figure 5-33: 4UDLT/FO/Phone System Configuration Display	23
Figure 5-34: 4UDLT/FO/Switch System Configuration Display	23
Figure 5-35: Black Digital Trunk System Configuration Display	24
Figure 5-36: Black Digital Trunk B Configuration Display	24
Figure 5-37: Black Digital Subscriber Configuration Display	24
Figure 5-38: 4-TRK/56K/Master System Configuration Display	24
Figure 5-39: 4-TRK/56K/Slave System Configuration Display	25
Figure 5-40: 4-TRK/64K/Master System Configuration Display	25
Figure 5-41: 4-TRK/64K/Slave System Configuration Display	25
Figure 5-42: 4-TRK/128K/Master System Configuration Display	25
Figure 5-43: 4-TRK/128K/Slave System Configuration Display	25
Figure 5-44: 4-TRK/256K/Master System Configuration Display	25
Figure 5-45: 4-TRK/256K/Slave System Configuration Display	25
Figure 5-46: 4-TRK/512K/Master System Configuration Display	25
Figure 5-47: 4-TRK/512K/Slave System Configuration Display	26
Figure 5-48: 4-TRK/FiberOptic System Master Configuration Display	26
Figure 5-49: 4-TRK/FiberOptic System Slave Configuration Display	26
Figure 5-50: System Parameter Modification Menu	27
Figure 5-51: Data Interface Configuration	27
Figure 5-52: Data Rate Configuration	28
Figure 5-53: Fast Ethernet IP Configuration	28
Figure 5-54: 10 Base-T Configuration	28
Figure 5-55: Network Configuration	28
Figure 5-56: Network Data Rate	29
Figure 5-57: Resync Frequency Configuration	29
Figure 5-58: Resync Delay Configuration	29
Figure 5-59: Resync Inversion Configuration	29
Figure 5-60: MDA-A Inter-MDA Communications Configuration	29
Figure 5-61: Remote Report Rate Configuration	30
Figure 5-62: SNMP IP Address Configuration	30
Figure 5-63: SNMP Port Configuration	30
Figure 5-64: Error Rate Configuration	30
Figure 5-65: Error Count Configuration	31
Figure 5-66: Error Count Trap Configuration	31
Figure 5-67: Error Rate Trap Configuration	31
Figure 5-68: UDLT 1 Trap Configuration	31
Figure 5-69: UDLT 2 Trap Configuration	32
Figure 5-70: UDLT 3 Trap Configuration	32
Figure 5-71: UDLT 4 Trap Configuration	32
Figure 5-72: Fail Duration Configuration	32
Figure 5-73: Fade Duration Configuration	32
Figure 5-74: Chatter Duration Configuration	32
Figure 5-75: Remote MDA UDLT Status Display (port up or down)	33
Figure 5-76: Remote MDA UDLT Valid Data Ports	33
Figure 5-77: Remote MDA UDLT Long Haul Communications	33
Figure 5-78: Remote MDA Board Support Package Part Number and Revision Display	34

Figure 5-79: Remote MDA Application Code Segment Part Number and Revision Display	34
Figure 5-80: Remote MDA Application Code Segment Part Number and Revision Display	34
Figure 5-81: Remote MDA Digital Signal Processor Part Number and Revision Display	34
Figure 5-82: Remote MDA FPGA Part Number Display.....	35
Figure 5-83: Remote MDA CPLD Part Number Display.....	35
Figure 5-84: Remote MDA Internal Temperature Display.....	35
Figure 5-85: Remote MDA Serial Number Display	35
Figure 5-86: Remote MDA 100 Mbit Ethernet Address Display	35
Figure 5-87: Remote MDA 10 Mbit Ethernet Address Display	36
Figure 5-88: Remote MDA Operating Mode	36
Figure 5-89: Remote MDA ReSync Count	36
Figure 5-90: Remote MDA ReCenter Count.....	36
Figure 5-91: Detailed MDA Menu – Statistics Info and System Config	37
Figure 5-92: Detailed MDA Menu – System Parm Edit.....	38
Figure 5-93: Detailed MDA Menu – Remote Status.....	39
Figure 6-1: J3/J8 External Wiring for Alarm	42
Figure 8-1: MDA Software Download Setup.....	44

Table of Tables

Table 3-1: MDA-A Rear Panel Connector Definition and Mate	5
Table 5-1: MDA Configurations and Displays – BRAVO, 4UDLT	20
Table 5-2: MDA Configurations and Displays – Black Digital, 4 Trunk.....	20
Table 6-1: “Single Ended” Resync Pin Definitions.....	40
Table 6-2: “Differential” Resync Pin Definitions.....	40
Table 6-3: Valid Settings for User Configurable Crypto Resync/Link Configuration Parameters.....	41
Table 9-1: Connector J3, J8 - RS-232 Async/Sync, T1/E1, MIL-188-114 Interface and Alarm Closure	50
Table 9-2 : Connector J4, J9 – UDLT channels 1 & 2, 10/100 BaseT Ethernet Ports.....	51
Table 9-3: Connector J5, J10 – UDLT channels 3 & 4, 10 BaseT Ethernet Ports.....	52

READ THIS FIRST

Safety Information

Caution
ELECTRICAL SHOCK HAZARD. This equipment is to be serviced by trained personnel only.
DANGER HAZARDOUS VOLTAGES INSIDE. Voltage or current hazard sufficient to cause shock.
The manufacturer requires that the unit be grounded. Ground the unit by attaching a ground wire between a known earth ground and the ground stud, E1, of the unit prior to plugging in the unit. Grounding the unit helps protect against damage caused by static voltage buildup and removes the risk of electric shock.
Never use an extension cord that does not have an earth ground connection. Never use an adapter that does not have an earth ground connection. If necessary, always use a suitable ground adapter. If possible, ground that extra wire on the ground adapter. Never use extension cords with non-polarized plugs or ones with broken off ground pins. Never break off the ground pin on electric equipment.
Always plug the power cord into the MDA-A first. Only after plugging the power cord into the MDA-A, plug the three-pronged AC plug into an AC outlet and power up the unit.
To disconnect the cord, always pull it out by grasping the plug. Never pull it out by the cord.
To avoid the risk of electrical shock, do not remove the cover. There are no user serviceable parts inside. Refer servicing to qualified service personnel. Additionally, opening the unit's cover, changing or modifying the equipment by the user (unless expressly approved by the manufacturer) shall void the warranty.
Use only the power supply cord supplied with the product. The MDA-A is equipped with two alternating-current line plugs. This plug will fit into the power outlet only one way. This is a safety feature. Warning: To prevent a shock hazard, do not modify the construction of the power cords.
Warning: To prevent fire or shock hazard, do not expose the unit to rain, moisture or corrosive gases.
Utilize safety precautions when installing the MDA-A. Follow the power installation directions carefully. The MDA-A like other home electronics contains hazardous voltages, do not attempt to open the MDA-A to service the unit. There are no user serviceable parts inside the MDA-A. If a failure occurs, please return through your RMA supply chain.
Operate the unit with the specified voltage. Using the wrong voltage risks fire and electrical shock.
At the first sign of smoke, an unusual smell or other problems indicating breakdown, disconnect external power cords. Should any solid or liquid fall into the unit, disconnect the AC power cord and have unit professionally checked before operating the unit again. Continued use risks fire and electrical shock.
Ventilation openings must not be blocked or covered. Air intake and exhaust openings are provided for ventilation and to ensure reliable operation of the product and to protect it from overheating.
Always make sure connectivity matches that chosen in System Configuration Display. When configured for phones, the unit supplies power. Therefore improper connectivity could damage connected equipment as well as risk fire and electrical shock.

1 Initial Configuration

Prior to connecting the MDA 1 (J5) or MDA 2 (J10) 10Mbit or MDA 1 (J4) or MDA 2 (J9) 10/100Mbit interfaces to a user's data network, the IP addresses should be configured with the user's network IP addressing scheme. Refer to the section called "Modifying the MDA Ethernet Addresses", on page 33, to configure the IP addresses.

When changing the system configuration: Once the user presses the SELECT key to make the change permanent, the hardware/software will be reconfigured. **Because 48V phone power is supplied by the MDA in some modes, it is best to configure the MDA when it is disconnected from all external equipment.** Once the SELECT key is pressed, allow the unit a few minutes to reconfigure the system configuration. When system reconfiguration is complete, power the unit OFF/ON to set the unit in its new operating mode.

2 Product Description

The Dual Multi-Function Digital Adapter - Aircraft (**MDA-A**) is equipped with two independent Multi-Functional Digital Adapters (MDA) in a chassis suited for an aircraft environment. The MDA-A uses the same software/firmware as the MDA and is fully interoperable with the MDA for all modes of operation. Access to the internal MDA outputs are provided by circular connectors on the rear panel of the MDA-A. The MDA display and keypad functions are located on the front panel of the MDA-A. A data capability exists that allows secure data to be transported through the Raytheon SDS or DSS switch by robbing the voice bandwidth. This data capability utilizes the existing security authentication procedures (SALs), provided by the Raytheon switch, to provide an authenticated multi-level secure data capability.

Another capability provided by the MDA is a Simple Network Management Protocol (**SNMP**) agent. This agent allows the target (MDA) to be configured and/or queried remotely by an SNMP manager. The SNMP manager can query the MDA to determine near real-time failure and status information that can provide valuable information to technicians that are diagnosing and correcting network problems.

3 Specifications

3.1 Physical Characteristics

The MDA-A chassis is a 17.5" x 17.5" x 3.46" metal enclosure as shown in Figure 3-1.

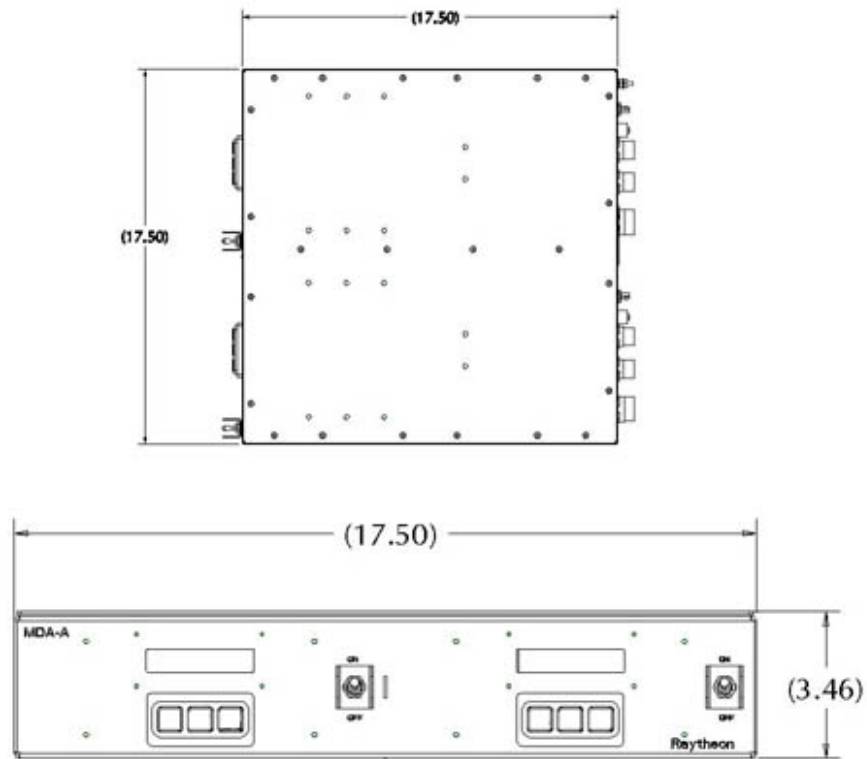

Figure 3-1: MDA-A Physical Dimensions (in inches)

3.1.1 MDA-A Front Panel

The MDA-A front panel includes two power on/off switches, two LCD display's, and two three-button keypad interface's. The LCD is a 2 by 16 character display that provides real time display of network alarm/link status and MDA mode information. Figure 3-2 is a graphic representation of the MDA-A front panel.

3.1.1.1 Keypad

The MDA provides three defined keys for the user input and query of run-time characteristics. The first key is defined to be the "SCROLL" key and allows the user to "scroll" through the menu items contained in the MDA. The second key is the "SELECT" key, which causes the system to take an action. The third key is defined as the "PREV MENU" key provides a method for the user to "escape" or "back out" of a given sequence.

3.1.1.2 LCD Display

The LCD is a 2-line, 16-character display that provides status and allows the user to provision the MDA.



Figure 3-2: MDA-A Front Panel

3.1.2 MDA-A Rear Panel

Figure 3-3 provides a graphic illustration of the rear panel of the MDA-A. The 360 degree triple thread coupling locking mechanism of the circular MIL-C-38999 series jacks provides external cabling with a secure mounting to protect them from extreme environmental conditions. The TX and RX fiber connectors are ST type. Table 3-1 summarizes the rear panel connector types and functions.



Figure 3-3: MDA-A Rear Panel

Connector Designation	Connector Manufacturer	Connector Function	Connector P/N	Connector Mate
J1, J2	Amphenol	Power	MS3102A10SL	MS3106A10SL-3S
J3, J8	ITT-Cannon	RS232 Sync/Async, MIL-188-114 Spare RS-422 and RS-232	D38999/20FE35PN	D38999/26FE35SN (straight) M85049/38-17N (backshell)
J4, J9	ITT-Cannon	10/100BaseT Ethernet UDLT 1 UDLT 2	D38999/20FC35PN	D38999/26FC35SN (straight) M85049/38-13N (backshell)
J5, J10	ITT-Cannon	10BaseT Ethernet UDLT 3 UDLT 4	D38999/20FC35PN	D38999/26FC35SN (straight) M85049/38-13N (backshell)
J6, J11	AMP	Optical Fiber RX interface 62.5/125um multimode (1300 nm)	504021-1	L-Com SFOST-xx or FODSTC50-xx or equivalent (xx denotes length m)
J7, J12	AMP	Optical Fiber TX interface 62.5/125um multimode (1300 nm)	504021-1	L-Com SFOST-xx or FODSTC50-xx or equivalent (xx denotes length m)
E1		Earth Ground Safety Stud	PPH 10-32 x 3/4	

Table 3-1: MDA-A Rear Panel Connector Definition and Mate

3.2 Security and Privacy

Since the MDA is located in locations where security is important, staff discipline is chosen as the security model rather than password protected accounts. The MDA does not have remote access. The MDA is a simple “pass-thru” device and does not authenticate information above layer 2. Protocol authentication is provided by the Multilink PPP (ML/PPP) protocol for point-to-point data transfer.

4 Functional Description

The MDA-A provides the following interfaces for each of the two MDAs.

MIL-188-114 Interface

The MDA's MIL-188-114 interface provides data rates of 56, 64, 128, 256 and 512 kbps.

Crypto Resync Interface

The MDA provides two distinct outputs (an RS232 and an RS422), which are controlled by the processor for the purpose of initiating a resynchronization to cryptographic equipment, connected to the MIL-188. The MDA application provides a one second pulse with configuration options for 5, 10, 15 and 20 seconds between resynchronizations pulses. The resynchronization logic can also be disabled.

Fiber Optic Interface

The MDA provides a 2.048 Mbps Fiber Optic link that can be selected as a Network interface.

Ethernet Interface

The MDA supports connectivity to a 10 Base-T (for data) and 100 Base-T (for SNMP) Fast Ethernet. The MDA's 10 Base T interface provides a "pass thru" mode allowing data from the Ethernet interface to be passed to the Network interface when the MDA is not specifically addressed.

Transparent Network Data Interface

The MDA provides Multilink PPP, which allows user data packets to be transmitted over the Network Interface. The ML/PPP will select as many available channels for transmission allowed by configuration. By allowing this capability, throughput on the network interface is variable up to an aggregate of about 1.344 Mbps.

UDLT Interface

The MDA provides four UDLT interfaces. When configured for this mode of operation, the MDA uses G.729 voice compression, reducing the transmission bandwidth requirements on the network interface to 8kbps per UDLT interface.

SNMP Interface

The MDA supports connectivity to Network Management System (NMS) using the Simple Network Management Protocol (SNMP) version 1c. Upon request from the NMS, the MDA will report IP, UDP, TCP, and MDA specific information. The IP, UDP, and TCP interface information will use the standard RFC 1155 and RFC 1213 MIB (Management Information Base). The MDA specific data will be reported under the Telecom enterprise MIB. The Telecom Private Enterprise number is 14116. The MDA will report status for a number of items including the operational mode, the link state, the link rate, the connection states, and the communication states. The MDA also provides traps to a Network Manager for specific faults/events.

The MDA will be delivered with a MIB that may be used by an NMS. The MIB will contain the MDA specific objects, as well as RFC 1155 and RFC 1213.

Crypto Alarm Interface

The MDA provides a relay contact alarm output for link failure when configured for Black Digital Subscriber or Trunk Modes.

4.1 MDA Interface Connectivity

The different interfaces available for MDA-A connectivity are shown below. An MDA in the Remote configuration (Phone End) operating in the Telecore Enhanced Mode provides four (4) UDLT interfaces, which service Raytheon end instruments. In addition, there is a 10 Base-T Ethernet interface allowing LAN connectivity “through” the MDA’s network interface. The MDA offers two network interfaces with a variety of bit rates available on each. The MIL-188-114 network interface is an RS-422 interface providing bit rates of 56/64/128/256/512 kbps.

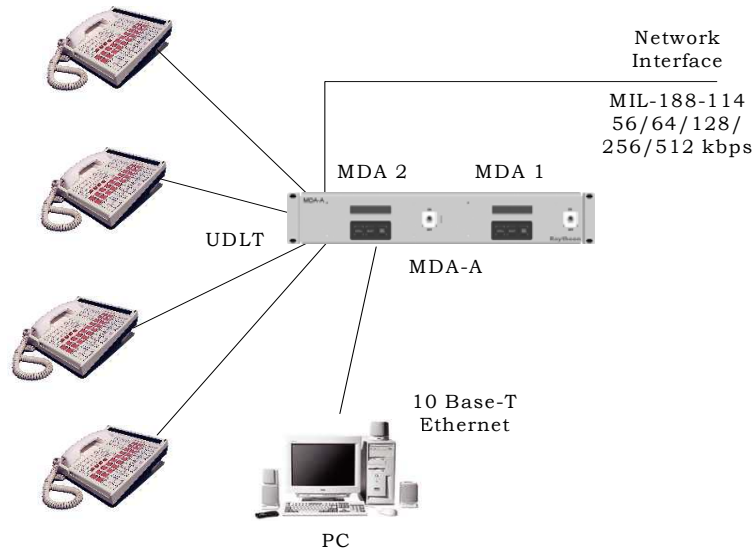

Figure 4-1: Phone Interface (Remote) MDA Configuration

Alternatively, a Fiber Optic network interface can be selected. The fiber network interface operates at a rate of 2.048Mbps. In addition to the operational four phones, this interface allows a data throughput bit rate up to 1.472 Mbps, not including the overhead of the Multilink PPP Protocol.

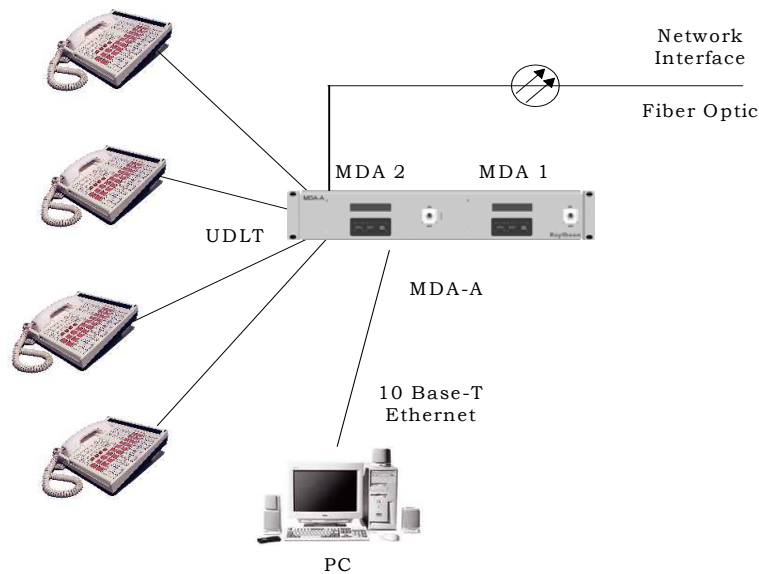

Figure 4-2: Fiber Optic Phone Interface (Remote) MDA Configuration

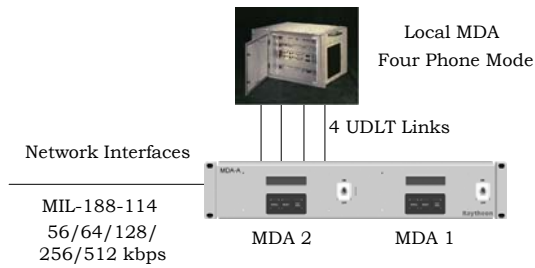

Figure 4-3: Switch Interface (Local) MDA-A Configuration

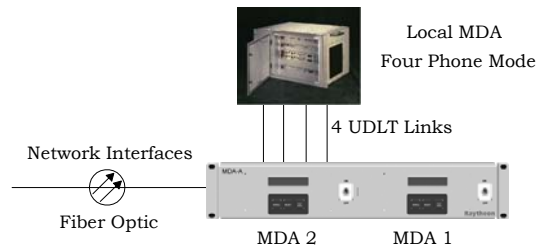

Figure 4-4: Fiber Optic Switch Interface (Local) MDA-A Configuration

In order to perform network management, a PC should be connected, via a LAN to the 100Mbit LAN connector (J4, MDA-1 and J9, MDA-2) of the MDA. On the PC, a program such as snmpTalk.exe should be loaded with the accompanying MDA MIB file, mib.rt. These files are available on Telecore's website www.telecore.com under the Software download section. Other Network Managers may also be used in support the MDA SNMP capability.

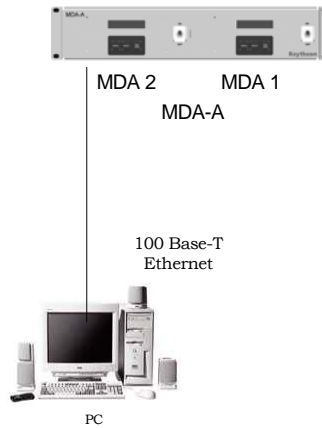

Figure 4-5: SNMP Connection to MDA

4.2 DTA/DPA Supported Operational Modes (Bravo)

The term “BRAVO” was used by the DTA/DPA to describe an enhanced operational mode for which the DTA/DPA was created. Bravo One mode provides two voice channels and no auxiliary data channels. Bravo Two mode provides one voice channel, and one 16Kbps point-to-point synchronous or one asynchronous channel, which can be configured for dial up voice-plus-data or point-to-point service.

4.2.1 Bravo One

Bravo One mode consists of a configuration of a Remote MDA connected to two Raytheon telephone devices, and a Local MDA connected to two interfaces (UDLT) of a Raytheon switching system. The MDA's are connected to each other via a 56 or 64 Kbps MIL-188-114 Interface.

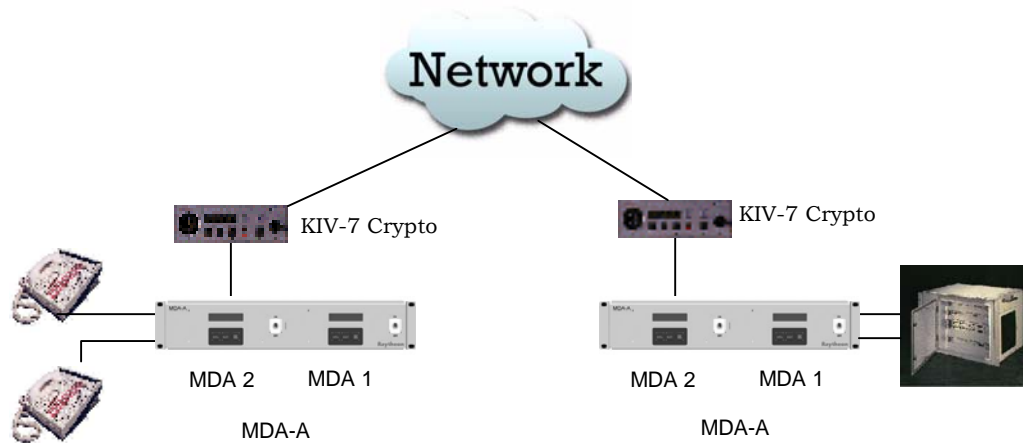

Figure 4-6: System level application of the MDA, BRAVO I MODE.

4.2.2 Bravo Two

Bravo Two mode is Bravo One mode with added data capabilities. The MDA's RS-232 port provides a low rate data passing capability. Data Mode is initiated at an MDA whenever the CTS/RTS external pins are asserted. The MDA senses this change and relays that information to the “other end” which in turn activates the proper Modem signals. The MDA goes back and forth between Bravo One and Bravo Two modes, based on the state of the CTS/RTS external pins. The data rates supported by the RS-232 interface are 16kbit synchronous, 9600 baud, 4800 baud, 2400 baud, 1200 baud, 600 baud and 300 baud asynchronous.

4.3 Four Phone Mode

Using state-of-the-art G.729 voice compression, as well as multiplexing of communications channels into available bandwidth, the MDA is capable of four phone operation consisting of a Remote MDA connected to four Raytheon telephone devices, or a Local MDA connected to four interfaces (UDLT) of a Raytheon switching system. The MDAs are connected to each other via a 56, 64, 128, 256 or 512 Kbps MIL-188-114 Interface or via the Fiber Optic Interface. This mode is not supported by the DTA/DPA and therefore requires an MDA to connect to another MDA in order to provide this feature.

4.4 Four Trunk Mode

Using the G.729 voice compression, as well as multiplexing of communications channels into available bandwidth, the MDA is capable of four trunk operation consisting of an MDA connected to four UDLT interfaces of a Raytheon switching system (configured for trunk operation) and another MDA connected to four interfaces (UDLT) of a Raytheon switching system probably at another location. The MDAs are connected to each other via a 56, 64, 128, 256 or 512 Kbps MIL-188-114 Interface or via the Fiber Optic Interface. Figure 4-7 shows a sample configuration using the MDA Four Trunk Mode implementation:

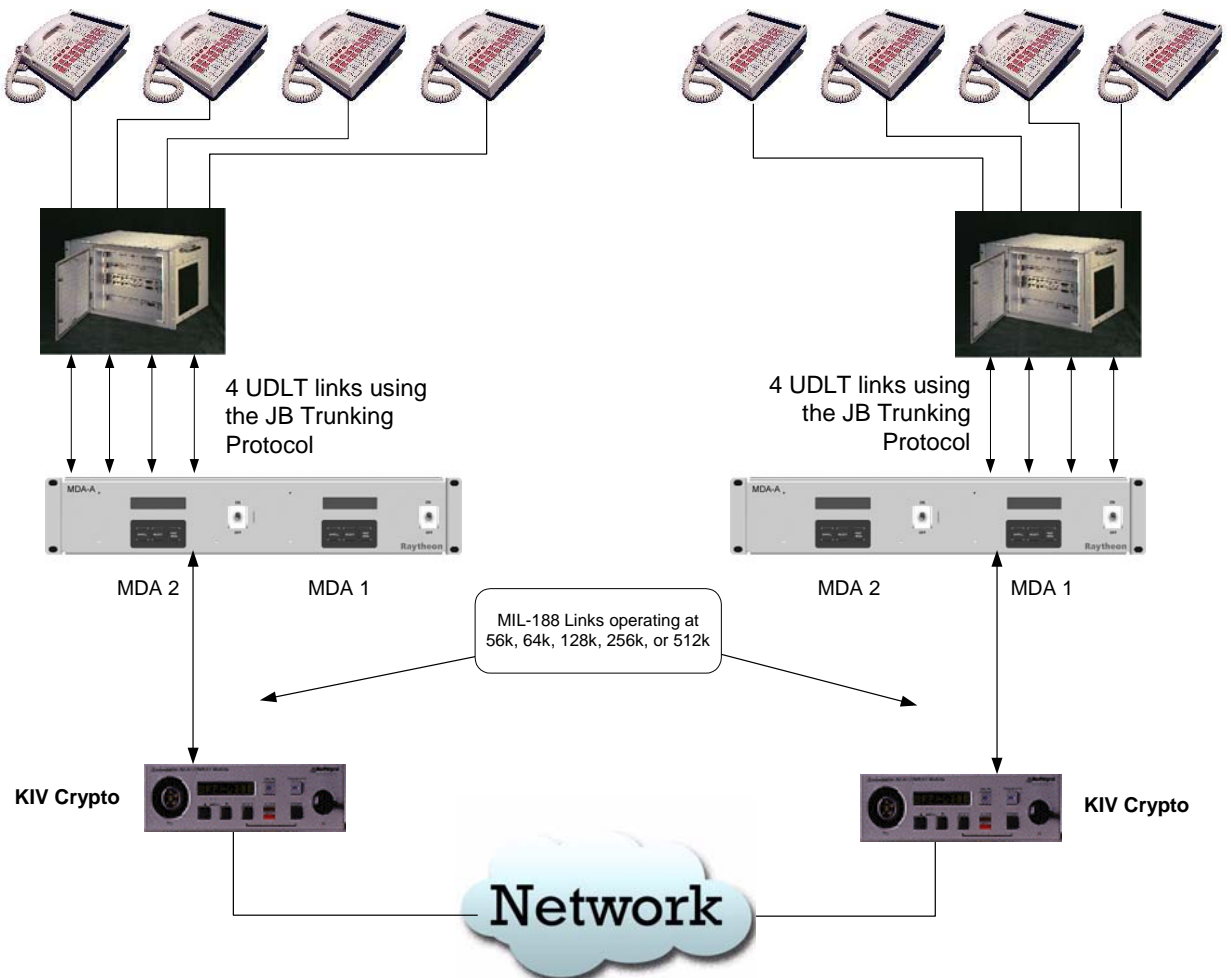

Figure 4-7: MDA Four Trunk Mode Configuration

4.5 MIL-188-114 Data Capabilities

In the Four Trunk and Four Phone modes of operation, the MDA is capable of accepting TCP/IP messages from the 10 Base-T Ethernet port and passing this information across the network interface. Conversely, the MDA is also capable of accepting TCP/IP messages from the network interface and passing them to the 10 Base-T Ethernet interface.

4.5.1 56/64 kbps

When operating at this bit rate, the MDA uses the voice timeslots of idle interfaces to transfer TCP/IP information. Each phone utilizes a single 8 kbps "timeslot", therefore yielding a maximum of 32 Kbps, not counting the overhead of the Multilink PPP Protocol.

4.5.2 128 kbps

When operating at this bit rate, the MDA uses the voice timeslots for idle interfaces to transfer TCP/IP information in addition to a 64 kbps "bulk" data channel, therefore yielding a maximum of 96 Kbps, not counting the overhead of the Multilink PPP Protocol.

4.5.3 256 kbps

When operating at this bit rate, the MDA uses the voice timeslots for idle interfaces to transfer TCP/IP information in addition to 3 - 64 kbps "bulk" data channels, therefore yielding a maximum of 224 Kbps, not counting the overhead of the Multilink PPP Protocol.

4.5.4 512 kbps

When operating at this bit rate, the MDA uses the voice timeslots for idle interfaces to transfer TCP/IP information in addition to 7 - 64 kbps "bulk" data channels, therefore yielding a maximum of 480 Kbps, not counting the overhead of the Multilink PPP Protocol.

4.6 Fiber Optic Data Capabilities

When operating in the Fiber Mode, the MDA uses 23 - 64 kbps "bulk" data channels to transfer TCP/IP information. This yields a maximum of 1.472 Mbps, not counting the overhead of the Multilink PPP Protocol.

4.7 Black Digital Subscriber/Trunk Mode

The MDA can also be configured to provide a single phone-to-switch or switch-to-switch interface. This configuration operates using a slow speed MIL-188 interface (4.8 kbps). As a Black Digital Trunk, the MDA provides a pass-thru of message (JB Protocol) on a single interface to a distant end MDA. The distant end MDA can be configured as a Black Digital Trunk B for switch-to-switch operation or Black Digital Subscriber for a single phone-to-switch interface. Figure 4-8 shows this switch-to-switch configuration for the Black Digital Trunk Mode.

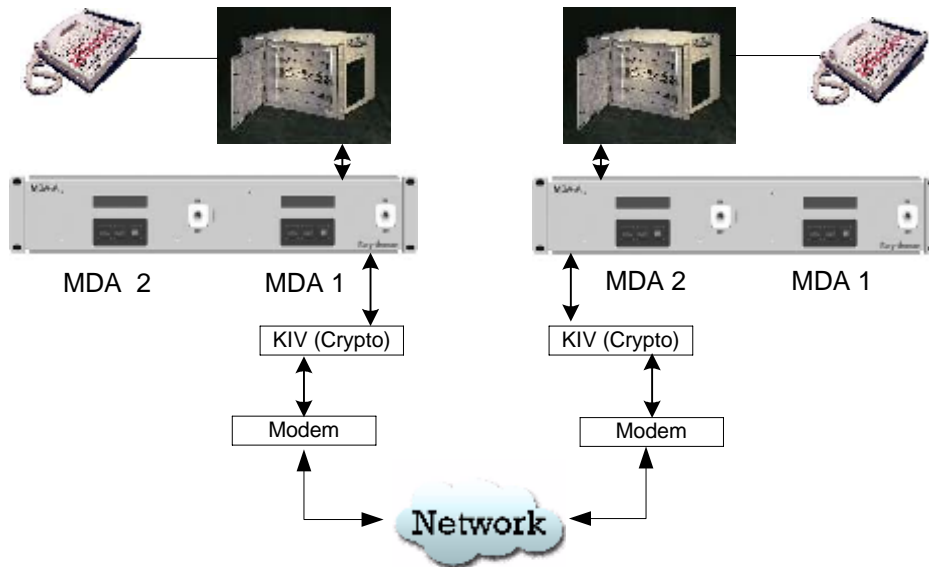

Figure 4-8: Black Digital Trunk Configuration

As a Black Digital Subscriber, the MDA accepts trunking protocol messages (JB protocol) and converts them to usable phone instructions allowing the phone instrument (IST-130, IST-2 or TXP) to operate as a trunk to the switching system. Configuration of the subscriber instrument can be done from the phone instrument or through a series of download files. The MDA is pre-configured for the basic SALs 2 through 9 and 15. Additional SAL mapping in the range of 10 through 99 may be supported by ftp'ing the file "salxx.dss" to the MDA, where xx is the SAL number in the range of 10 to 99. Consult Raytheon's DRSN support group for obtaining these SAL files from an authorized source. Figure 4-9 shows this switch to subscriber configuration for the Black Digital Subscriber Mode.

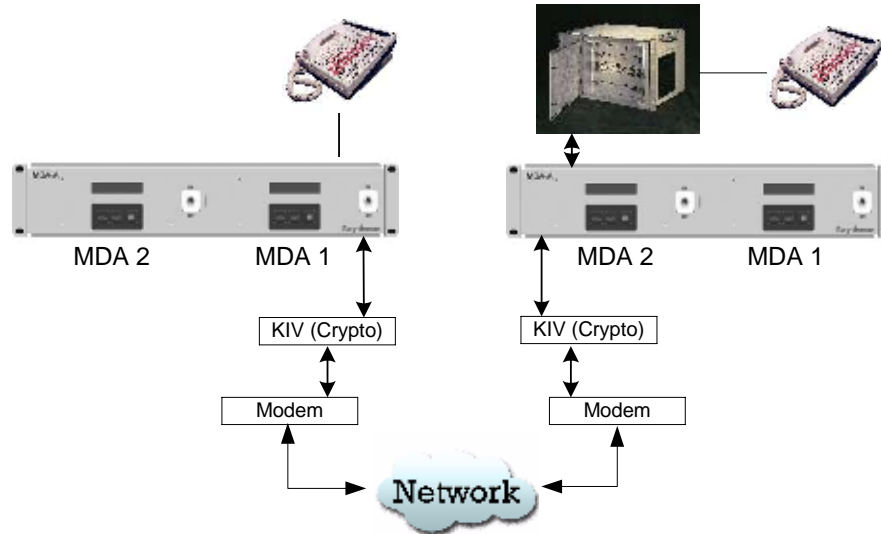

Figure 4-9: Black Digital Subscriber Configuration

4.8 Simple Network Management Protocol (SNMP)

The MDA provides a means for a network manager to query the status of the unit via the 100 Mb Fast Ethernet port. This capability is realized through the vxWorks SNMP subsystem. A MIB (Management Information Block) is loaded at run-time and can be addressed using the Telecore Private Enterprise Number. The number assigned to Telecore is **14116**. Therefore, addressing the variables of the MIB must incorporate this number. The SNMP subsystem for the MDA will report the various system status of the local MDA (and remote MDA for 4-Phone/4-Trunk modes) as well as allow MDA unit and special counter resets to be performed upon instruction from a Network Management System (NMS). The MDA reports the connectivity status for each of the UDLT links by querying the system to report the Valid Data bits of each UDLT link along with Long Haul Comms (LHC) connectivity status. In the Telecore only modes, the communication status is also available. The link rate and configuration of the MDA is also available via SNMP. SNMP manager queried status reporting includes much of the status available at the front panel of the MDA. The MDA also reports special events to a network Manager as traps/alarms, including UDLT link failures (all modes) and frame error count/rate (for Black Digital modes only).

5 Configuration

At initial power-up, the MDA User Interface will display the current status of the network link connected to the MDA. This display is referred to as the Status Display. Pressing the SCROLL key or the PREV MENU key will cause the MDA to enter the maintenance mode. Once in this mode, the user can examine as well as modify the run time database of the MDA. To exit the maintenance mode the user can press the PREV MENU key and “back out” to the Status Display.

5.1 Status Display

The Status Display is segmented into two areas. The top line is a counter display area and the bottom line is a link status area. The top line displays two counters labeled “RS” and “RC”. The “RS” counter is the number of re-synchronize operations that have occurred. The “RC” counter is the number of re-center operations that have occurred. Each of these values is a decimal number in the range of 0 – 9999. (*Note:* In 64 Kbps mode it is reflected by the use of the uppercase “RS” and “RC”. 56Kbps mode is designated by the use of lowercase “rs” and “rc”.) The higher rates are indicated in the upper left hand corner of the display (128, 256 and 512).

<u>56 Kbps</u>	<u>64 Kbps</u>	<u>128 Kbps</u>
rs= 0 rc= 0 BRAVO ONE	RS= 0 RC= 0 BRAVO ONE	128 RS= 0 RC= 0 BRAVO ONE
rs= 0 rc= 0 Out Of Sync	RS= 0 RC= 0 Out Of Sync	128 RS= 0 RC= 0 Out Of Sync
rs= 0 rc= 0 Rem Out Of Sync	RS= 0 RC= 0 Rem Out Of Sync	128 RS= 0 RC= 0 Rem Out Of Sync

Figure 5-1: Status Display Examples

The bottom line of the display indicates the current state of the network link. The indications valid for this area are:

“Out Of Sync”	Indicates that the MDA is not receiving a valid bit-stream from the distant end.
“Rem Out Of Sync”	Indicates that the MDA is receiving a valid synchronized bit-stream from the distant end; however, the distant end is informing the MDA that it is not receiving a valid bit-stream from the MDA.
“DSP Re-loading”	Indicates an internal re-sync of the DSP.
“BRAVO ONE”	Indicates that the MDA’s link is valid in both directions and that its mode of operation is “BRAVO ONE”.
“BRAVO TWO”	Indicates that the MDA’s link is valid in both directions and that its mode of operation is “BRAVO TWO”.
“4-PHONE”	Indicates that the MDA’s link is valid in both directions and that its mode of operation is “4-PHONE”.
“4-PHONE FIBER”	Indicates that the MDA’s link is valid in both directions and that its mode of operation is “4-PHONE FIBER”.

- "Blk Dig Trunk" Indicates that the MDA's link is valid in both directions to a switch and that its mode of operation is "Blk Dig Trunk".
- "Blk Dig Sub" Indicates that the MDA's link is valid in one direction to a switch and the other direction to an end instrument and that its mode of operation is "Blk Dig Sub".
- "4-TRUNK" Indicates that the MDA's link is valid in both directions and that its mode of operation is "4-TRUNK".
- "4-TRUNK FIBER" Indicates that the MDA's link is valid in both directions and that its mode of operation is "4-TRUNK FIBER".

5.2 User Interface Menu Map

The following illustrations show the displays and how to maneuver to each display. See section 5.7 for detailed front panel menus.

User Interface Menus

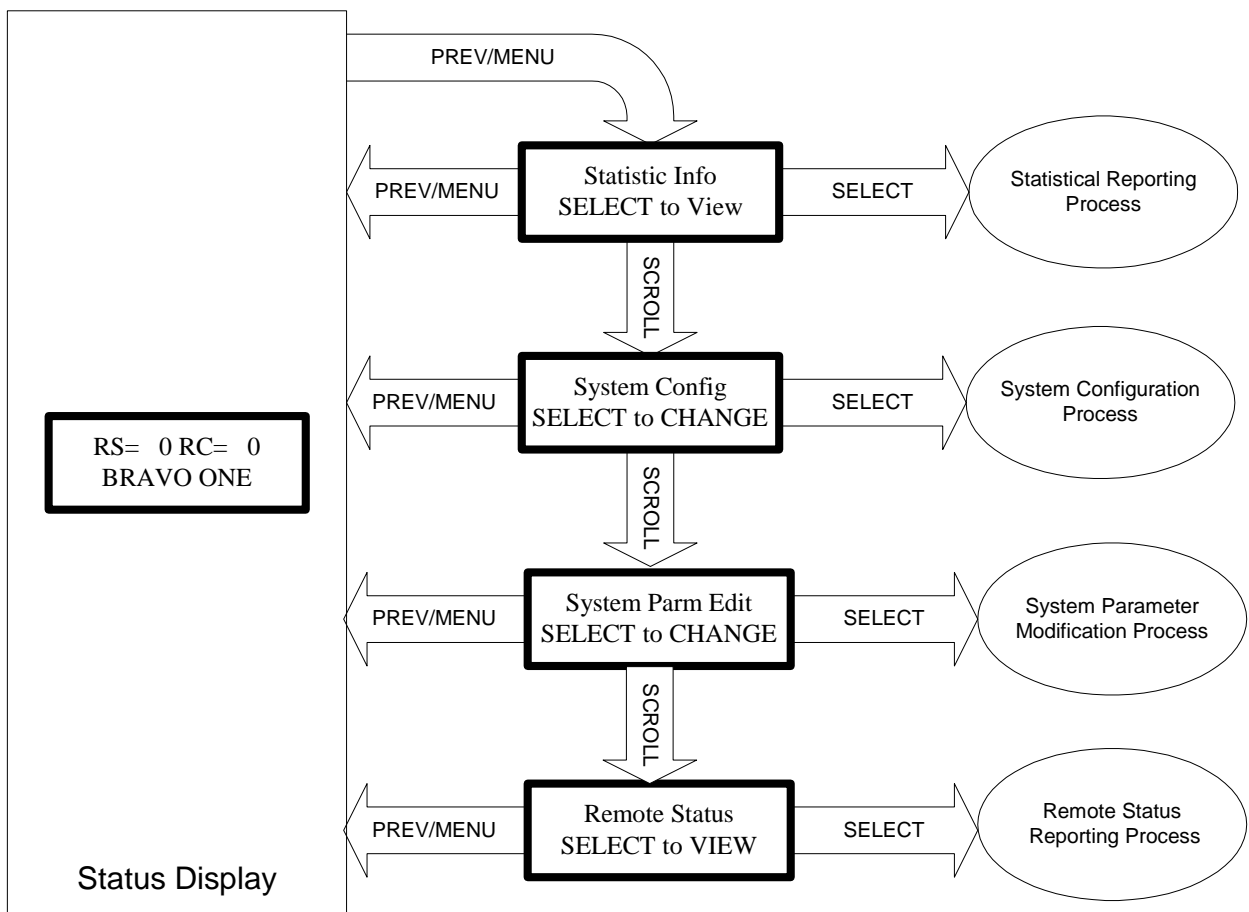

Figure 5-2: MDA User Menus

The Statistical Reporting Process Menus are detailed in the section 5.3 Statistic Information on page 16. The System Configuration Process Menus are detailed in the section 5.4 System Configuration on page 19. The System Parameter Process Menus are detailed in the section 5.5 System Parameter Modification Displays on page 27. The Remote Status Reporting Process Menus are detailed in the section 5.6 Remote Status Information on page 33.

5.3 Statistic Information

From the Status Display, pressing the SCROLL or PREV MENU keys will cause the MDA to enter the maintenance mode displaying the Statistic Display menu.

5.3.1 Statistic Display Menu

Pressing the PREV MENU key at this time will cause the MDA to exit the maintenance mode and return the MDA to the Status Display. Pressing the SCROLL key will move the user to the System Configuration Menu. Pressing the SELECT key will begin the display of statistical information of the MDA.

```

Statistic Info
SELECT to View
  
```

Figure 5-3: Statistic Display Menu

5.3.2 Statistic Information Displays

There are several displays in this section, which are displayed to the user in successive depressions of the SCROLL key. Exiting this “subsystem” is achieved by pressing the PREV MENU key and the user is returned to the Statistic Display Menu. The displays contained in the Statistic reporting subsystem are outlined below in the order in which they appear:

5.3.2.1 MDA UDLT Status Display

This display shows the current status of UDLT interfaces connected to the MDA. In Bravo mode, UDLT 1 and 2 shows connectivity of a UDLT device. Connectivity is ascertained by interrogating the VALID DATA (VD) bit provided by the UDLT chip set. The Long Haul Communications (LHC) display is invalid and will show a “down” indication. In 4-Phone and 4 Trunk modes, each UDLT link must be connected but also must be communicating using the LHC ACK/NACK messaging protocol. Each UDLT interface must be requesting data as well as answer the MDA’s requests for data in order to be “up” (as indicated by the direction of the arrow). VD and LHC up/down status is also provided individually for each UDLT channel. In Black Digital modes, only UDLT 1 is valid for UDLT, VD and LHC status.

```

UDLT: 1 2 3 4
      v ^ v v
  
```

Figure 5-4: MDA UDLT Status Display (port up or down)

```

UDLT: 1 2 3 4
VD    v ^ v v
  
```

Figure 5-5: MDA UDLT Valid Data Ports

```

UDLT: 1 2 3 4
LHC   v ^ v v

```

Figure 5-6: MDA UDLT Long Haul Communications

5.3.2.2 MDA BSP Part Number and Revision Display

This display shows the part number and the current revision of the Motorola 860 Power PC processor's Board Support Package (BSP).

```

MPC 860 BSP
2AA-00452-XX

```

Figure 5-7: MDA Board Support Package Part Number and Revision Display

5.3.2.3 MDA Application Part Number and Revision Display

This display shows the part number and the current revision of the Motorola 860 Power PC processor's Application code.

```

MPC 860 APL
2AA-00453-XX

```

Figure 5-8: MDA Application Code Segment Part Number and Revision Display

5.3.2.4 MDA Multilink PPP Application Part Number and Revision Display

This display shows the part number and the current revision of the Multilink Point to Point Protocol software running on the Motorola 860 Power PC processor. This software is not applicable for Black Digital modes.

```

MPC 860 MLPPP
2AA-00455-XX

```

Figure 5-9: MDA Application Code Segment Part Number and Revision Display

5.3.2.5 MDA DSP Part Number and Revision Display

This display shows the part number and the current revision of the firmware currently operating in the DSP. This part number is extracted from the DSP during operation. The 2AA-00459-XX is displayed in Bravo, 4-Phone and 4-Trunk modes; the 2AA-00428-XX is displayed in Black Digital modes.

```

DSP C5416
2AA-00459-XX

```

or

```

DSP C5416
2AA-00428-XX

```

Figure 5-10: MDA Digital Signal Processor Part Number and Revision Display

5.3.2.6 MDA FPGA Part Number Display

This display shows the part number and the current revision of the firmware currently loaded in the Fixed Programmable Gate Array. This part number is extracted from the FPGA during operation. The 2AA-00421-XX is displayed in Bravo, 4-Phone and 4-Trunk modes; the 2AA-00417-XX is displayed in Black Digital modes.

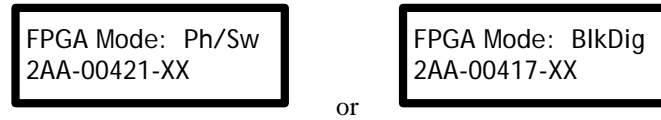

Figure 5-11: MDA FPGA Part Number Display

5.3.2.7 MDA CPLD Part Number Display

This display shows the part number and the current revision of the firmware currently loaded in the Complex Programmable Logic Device. This part number is extracted from the CPLD during operation.

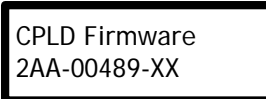

Figure 5-12: MDA CPLD Part Number Display

5.3.2.8 MDA Internal Temperature Display

This display shows the current temperature inside the MDA unit expressed in degrees Celsius.

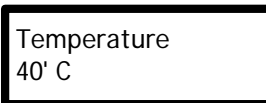

Figure 5-13: Internal Temperature Display

5.3.2.9 MDA Serial Number Display

This display shows the Serial number of the MDA unit programmed from the factory. This number should match the label on the MDA unit.

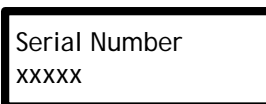

Figure 5-14: Serial Number Display

5.3.2.10 MDA 100 Mbit Ethernet Address Display

This display shows the current IP address of the MDA's 100 Mb Fast Ethernet port. This IP can be changed from the front panel and is covered in the System Parameter Edit section of this manual.

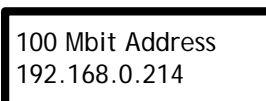
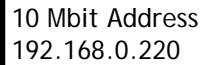

Figure 5-15: 100 Mbit Ethernet Address Display

5.3.2.11 MDA 10 Mbit Ethernet Address Display

This display shows the current IP address of the MDA's 10-Base T Ethernet port. This IP can be changed from the front panel and is covered in the System Parameter Edit section of this manual.



```
10 Mbit Address
192.168.0.220
```

Figure 5-16: 10 Mbit Ethernet Address Display

5.3.2.12 MDA Product Manufacturer Information Display

This display shows the MDA product manufacturer information.

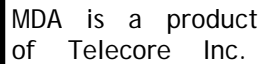

```
MDA is a product
of Telecore Inc.
```

Figure 5-17: Product Manufacturer Information

5.4 System Configuration

From the Statistical Display, pressing the SCROLL key will cause the MDA to remain in the maintenance mode and display the System Configuration menu.

5.4.1 System Configuration Menu

Pressing the PREV MENU key at this time will cause the MDA to exit the maintenance mode and return the MDA to the Status Display. Pressing the SCROLL key will move the user to the System Parameter Edit Menu. Pressing the SELECT key will enter the MDA into a System provisioning mode.

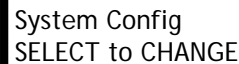

```
System Config
SELECT to CHANGE
```

Figure 5-18: System Configuration Menu

5.4.2 System Configuration Display

On this display, the current configuration is displayed on the top line and the bottom line indicates one of two possible operations. If the bottom line displays "Scroll for Options" then the currently displayed value on the top line of the display is the current value of the system mode. If the bottom line displays "SELECT to SAVE", the user can press the SELECT key to make the change permanent or press the SCROLL key to view the other possible configurations. Pressing the PREV MENU key at any time returns the user to the

The MDA allows selection of the mode (Bravo, 4 UDLT, 4 Trunk, Black Digital), rate (56 Kbps, 64 Kbps, 128 Kbps, 256 Kbps or 512 Kbps over the MIL-188-114 link or FO over the fiber optic network link) and interface (phone, switch, trunk master, trunk slave, and black digital trunk, black digital trunk B and black digital subscriber). Several possible MDA configurations and the displays are outlined below in the order in which they appear.

BRAVO (56 or 64 Kbps only) over MIL-188-114 only	4 UDLT (56/64/128/256/512 Kbps) over MIL-188-114	4 UDLT over Fiber Optic
Bravo/56 kbps/Phone	4 UDLT/56 kbps/Phone	4 UDLT/FO/Phone
Bravo/56 kbps/Switch	4 UDLT/56 kbps/Switch	4 UDLT/FO/Switch
Bravo/64 kbps/Phone	4 UDLT/64 kbps/Phone	
Bravo/64 kbps/Switch	4 UDLT/64 kbps/Switch	
	4 UDLT/128 kbps/Phone	
	4 UDLT/128 kbps/Switch	
	4 UDLT/256 kbps/Phone	
	4 UDLT/256 kbps/Switch	
	4 UDLT/512 kbps/Phone	
	4 UDLT/512 kbps/Switch	

Table 5-1: MDA Configurations and Displays – BRAVO, 4UDLT

BLACK DIGITAL (4.8 Kbps only) over MIL-188-114 only	4 TRUNK (56/64/128/256/512 Kbps) over MIL-188-114	4 TRUNK over Fiber Optic
Black Digital Trunk	4-TRK/56 kbps/Master	4-TRK/FiberOptic/Master
Black Digital Trunk B	4-TRK/56 kbps/Slave	4-TRK/FiberOptic/Slave
Black Digital Subscriber	4-TRK/64 kbps/Master	
	4-TRK/64 kbps/Slave	
	4-TRK/128 kbps/Master	
	4-TRK/128 kbps/Slave	
	4-TRK/256 kbps/Master	
	4-TRK/256 kbps/Slave	
	4-TRK/512 kbps/Master	
	4-TRK/512 kbps/Slave	

Table 5-2: MDA Configurations and Displays – Black Digital, 4 Trunk

Please note, when changing the system configuration: Once the user presses the SELECT key to make the change permanent, the hardware/software will be reconfigured. Because 48V phone power is supplied by the MDA in some modes, it is best to configure the MDA when it is disconnected from all external equipment. Once the SELECT key is pressed, allow the unit a few minutes to reconfigure the system configuration. When system reconfiguration is complete, power the unit OFF/ON to set the unit in it's new operating mode.

5.4.2.1 BRAVO

This selection configures the MDA for Bravo mode, which uses the MIL-188-114 network link. The MIL-188-114 link can be configured for either 56 Kbit operation or 64 Kbit operation (as selected). Hardware and Software are configured to support two switch or phone interfaces (as selected) using,

MDA 1: UDLT connector J4 (UDLT1 primary and UDLT 2 secondary) or

MDA 2: UDLT connector J9 (UDLT1 primary and UDLT 2 secondary).

Because power is supplied by the MDA in the phone mode, please verify that your configuration matches Figure 4-1: Phone Interface (Remote) MDA Configuration on page 7 (with only two phones) before selecting this mode. Improper connectivity could damage sensitive electronic parts.

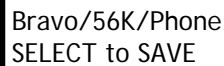

Bravo/56K/Phone
SELECT to SAVE

Figure 5-19: Bravo/56K/Phone System Configuration Display

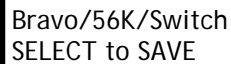

Bravo/56K/Switch
SELECT to SAVE

Figure 5-20: Bravo/56K/Switch System Configuration Display

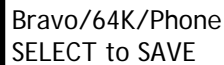

Bravo/64K/Phone
SELECT to SAVE

Figure 5-21: Bravo/64K/Phone System Configuration Display

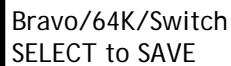

Bravo/64K/Switch
SELECT to SAVE

Figure 5-22: Bravo/64K/Switch System Configuration Display

5.4.2.2 4 UDLT, MIL-188-114

This group of selections configures the MDA for 4 Phone mode, using the MIL-188-114. This link can be configured for 56 Kbit, 64 Kbit, 128 Kbit, 256 Kbit or 512 Kbit operation (as selected). Hardware and Software are configured to support four switch or phone interfaces (as selected) using,

MDA 1: UDLT connectors J4 (UDLT1 and UDLT2) and J5 (UDLT3 and UDLT4) or

MDA 2: UDLT connectors J9 (UDLT1 and UDLT2) and J10 (UDLT3 and UDLT4).

Because power is supplied by the MDA in the phone mode, please verify that your configuration matches Figure 4-1: Phone Interface (Remote) MDA Configuration on page 7 before selecting this mode. Improper connectivity could damage sensitive electronic parts.

4UDLT/56K/Phone
SELECT to SAVE

Figure 5-23: 4UDLT/56K/Phone System Configuration Display

4UDLT/56K/Switch
SELECT to SAVE

Figure 5-24: 4UDLT/56K/Switch System Configuration Display

4UDLT/64K/Phone
SELECT to SAVE

Figure 5-25: 4UDLT/64K/Phone System Configuration Display

4UDLT/64K/Switch
SELECT to SAVE

Figure 5-26: 4UDLT/64K/Switch System Configuration Display

4UDLT/128K/Phone
SELECT to SAVE

Figure 5-27: 4UDLT/128K/Phone System Configuration Display

4UDLT/128K/Switch
SELECT to SAVE

Figure 5-28: 4UDLT/128K/Switch System Configuration Display

4UDLT/256K/Phone
SELECT to SAVE

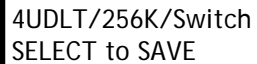
Figure 5-29: 4UDLT/256K/Phone System Configuration Display

 A rectangular box with a black border containing the text:

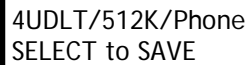
```
4UDLT/256K/Switch
SELECT to SAVE
```

Figure 5-30: 4UDLT/256K/Switch System Configuration Display

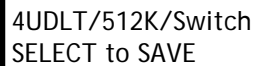
 A rectangular box with a black border containing the text:

```
4UDLT/512K/Phone
SELECT to SAVE
```

Figure 5-31: 4UDLT/512K/Phone System Configuration Display

 A rectangular box with a black border containing the text:

```
4UDLT/512K/Switch
SELECT to SAVE
```

Figure 5-32: 4UDLT/512K/Switch System Configuration Display

5.4.2.3 4 UDLT, Fiber Optic

This selection configures the MDA for 4 Phone mode, using the Fiber Optic Network link. Hardware and Software are configured to support four switch or phone interfaces (as selected) using,

MDA 1: UDLT connectors J4 (UDLT1 and UDLT2) and J5 (UDLT3 and UDLT4) or

MDA 2: UDLT connectors J9 (UDLT1 and UDLT2) and J10 (UDLT3 and UDLT4).

Because power is supplied by the MDA in the phone mode, please verify that your configuration matches Figure 4-2: Fiber Optic Phone Interface (Remote) MDA Configuration on page 7 before selecting this mode. Improper connectivity could damage sensitive electronic parts.

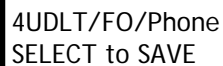
 A rectangular box with a black border containing the text:

```
4UDLT/FO/Phone
SELECT to SAVE
```

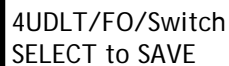
Figure 5-33: 4UDLT/FO/Phone System Configuration Display

 A rectangular box with a black border containing the text:

```
4UDLT/FO/Switch
SELECT to SAVE
```

Figure 5-34: 4UDLT/FO/Switch System Configuration Display

5.4.2.4 Black Digital

This group of selections configures the MDA for Black Digital Mode, using the MIL-188-114 network link. Choosing this selection forces the network link to 4.8 kbps. Hardware and Software are configured to support either a Black Digital Trunk, a Black Digital Trunk B, or a Black Digital Subscriber using,

MDA 1: UDLT connector J4 (UDLT1) or

MDA 2: UDLT connector J9 (UDLT1).

In switch-to-switch mode one side must be configured as Black Digital Trunk and the other side must be configured as Black Digital Trunk B. In Black Digital Subscriber mode the switch side must be configured as Black Digital Trunk and the phone side must be configured as Black Digital Subscriber.

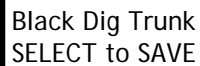

Black Dig Trunk
SELECT to SAVE

Figure 5-35: Black Digital Trunk System Configuration Display

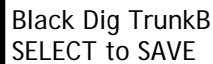

Black Dig TrunkB
SELECT to SAVE

Figure 5-36: Black Digital Trunk B Configuration Display



Black Dig Subscriber
SELECT to SAVE

Figure 5-37: Black Digital Subscriber Configuration Display

5.4.2.5 4 Trunk, MIL-188-114

This group of selections configures the MDA for 4 Trunk mode, using the MIL-188-114. This link can be configured for 56 Kbit, 64 Kbit, 128 Kbit, 256 Kbit or 512 Kbit operation (as selected). One side is configured as Master and the other side is configured as Slave. Hardware and Software are configured to support four inter-switch interfaces (as selected) using,

MDA 1: UDLT connectors J4 (UDLT1 and UDLT2) and J5 (UDLT3 and UDLT4) or

MDA 2: UDLT connectors J9 (UDLT1 and UDLT2) and J10 (UDLT3 and UDLT4).

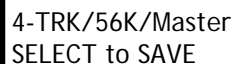

4-TRK/56K/Master
SELECT to SAVE

Figure 5-38: 4-TRK/56K/Master System Configuration Display

4-TRK/56K/Slave
SELECT to SAVE

Figure 5-39: 4-TRK/56K/Slave System Configuration Display

4-TRK/64K/Master
SELECT to SAVE

Figure 5-40: 4-TRK/64K/Master System Configuration Display

4-TRK/64K/Slave
SELECT to SAVE

Figure 5-41: 4-TRK/64K/Slave System Configuration Display

4-TRK/128K/Master
SELECT to SAVE

Figure 5-42: 4-TRK/128K/Master System Configuration Display

4-TRK/128K/Slave
SELECT to SAVE

Figure 5-43: 4-TRK/128K/Slave System Configuration Display

4-TRK/256K/Master
SELECT to SAVE

Figure 5-44: 4-TRK/256K/Master System Configuration Display

4-TRK/256K/Slave
SELECT to SAVE

Figure 5-45: 4-TRK/256K/Slave System Configuration Display

4-TRK/512K/Master
SELECT to SAVE

Figure 5-46: 4-TRK/512K/Master System Configuration Display

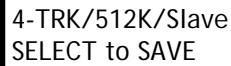

4-TRK/512K/Slave
SELECT to SAVE

Figure 5-47: 4-TRK/512K/Slave System Configuration Display

5.4.2.6 4 Trunk, Fiber Optic

This selection configures the MDA for 4 Trunk mode, using the Fiber Optic Network link. One side is configured as Master and the other side is configured as Slave. Hardware and Software are configured to support four inter-switch interfaces (as selected) using,

MDA 1: UDLT connectors J4 (UDLT1 and UDLT2) and J5 (UDLT3 and UDLT4) or

MDA 2: UDLT connectors J9 (UDLT1 and UDLT2) and J10 (UDLT3 and UDLT4).

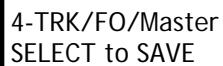

4-TRK/FO/Master
SELECT to SAVE

Figure 5-48: 4-TRK/FiberOptic System Master Configuration Display

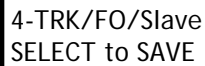

4-TRK/FO/Slave
SELECT to SAVE

Figure 5-49: 4-TRK/FiberOptic System Slave Configuration Display

5.5 System Parameter Modification Displays

From the System Configuration Menu, pressing the SCROLL key will cause the MDA to enter the maintenance mode displaying the System Parameter Modification Menu. This subsystem will allow the user to examine or modify the settings not configured by the System Configuration subsystem

5.5.1 System Parameter Modification Menu

Pressing the PREV MENU key or the SCROLL key at this time will cause the MDA to exit the maintenance mode and return the MDA to the Status Display. Pressing the SELECT key will begin the display of System Settings available for user modification.

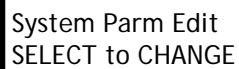

System Parm Edit
SELECT to CHANGE

Figure 5-50: System Parameter Modification Menu

5.5.2 System Parameter Modification Displays

There are several elements in this section, each of which are displayed to the user in successive depressions of the SCROLL key. Selecting any parameter for modification causes the subsystem to display the current value of the parameter on the top line and user interaction on the bottom line. The bottom line of the display instructs the user as has been previously described. The SCROLL key allows the user to scroll through the possible selections, the SELECT key permanently saves the setting. In the event that the parameter being viewed is “locked” from modification the message “Modification N/A” is displayed. Exiting this “subsystem” is achieved by pressing the PREV MENU key returning the user to the System Parameter Modification Menu. The displays contained in the System Parameter Modification subsystem are outlined below in the order in which they appear:

5.5.2.1 Data Interface

This display allows the MDA's data interface to be configured. The selection options available are RS-232 and Ethernet.

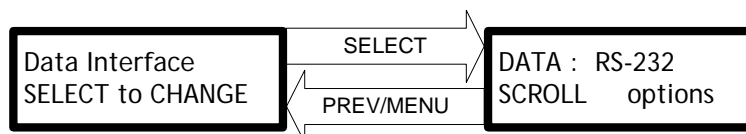

Figure 5-51: Data Interface Configuration

5.5.2.2 Data Rate

This display allows the MDA's data interface rate to be configured. The selection options are based on the configured data interface. For RS-232, the selection options are: Sync, 300, 600, 1200, 2400, 4800, and 9600. For Ethernet, the only selection option is 10Mb.

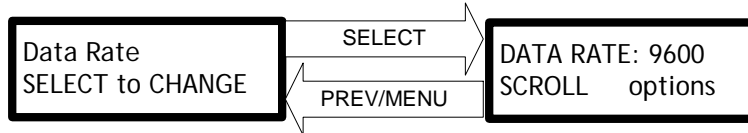

Figure 5-52: Data Rate Configuration

5.5.2.3 100 Base-T IP Address

This display allows the MDA's local 100MB IP address to be modified.

Refer to section 5.5.3 for more information on modifying the MDA Ethernet address.

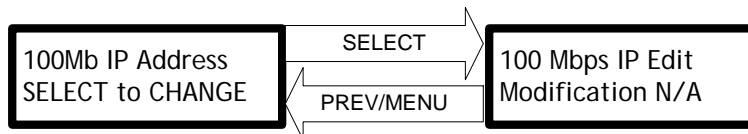

Figure 5-53: Fast Ethernet IP Configuration

5.5.2.4 10 Base-T IP Address

This display allows the MDA's local 10MB IP address to be modified.

Refer to section 5.5.3 for more information on modifying the MDA Ethernet address.

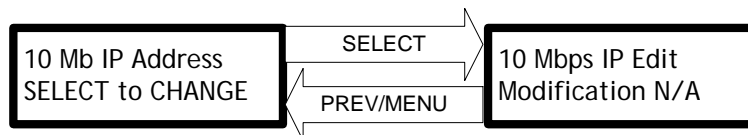

Figure 5-54: 10 Base-T Configuration

5.5.2.5 Network

This display allows the MDA's network interface type to be configured.

Note: This parameter is automatically configured by using the System Configuration Menu detailed in section 5.4

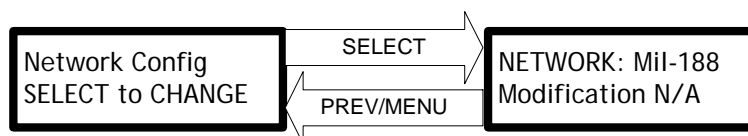

Figure 5-55: Network Configuration

5.5.2.6 Network Data Rate

This display allows the MDA's network interface data rate to be configured.

Note: This parameter is automatically configured by using the System Configuration Menu detailed in section 5.4

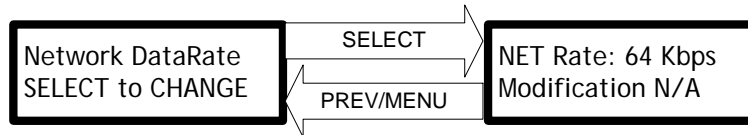

Figure 5-56: Network Data Rate

5.5.2.7 Resync Frequency

Refer to section **Error! Reference source not found.** for details on this parameter.

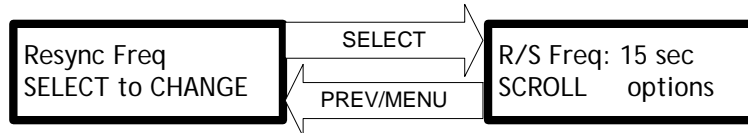

Figure 5-57: Resync Frequency Configuration

5.5.2.8 Resync Delay

Refer to section **Error! Reference source not found.** for details on this parameter.

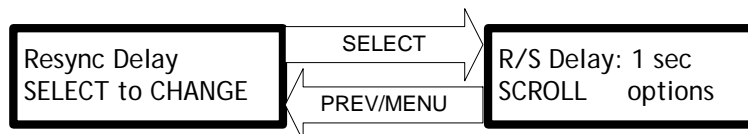

Figure 5-58: Resync Delay Configuration

5.5.2.9 Resync Inversion

Refer to section **Error! Reference source not found.** for details on this parameter.

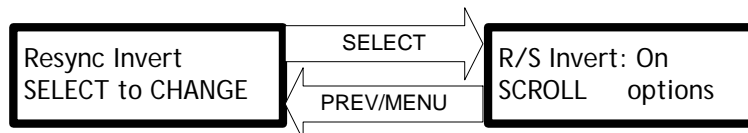

Figure 5-59: Resync Inversion Configuration

5.5.2.10 Inter-MDA Communications

Refer to section **Error! Reference source not found.** for details on this parameter.

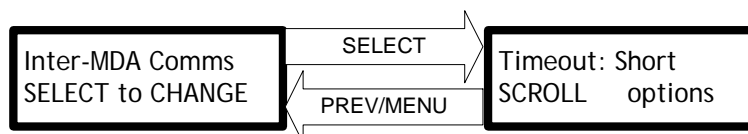

Figure 5-60: MDA-A Inter-MDA Communications Configuration

5.5.2.11 Remote Report Rate

This display allows the MDA's remote reporting rate to be configured. This is the rate that SNMP-related information is updated over the link between MDAs. The selection options available are 1, 2, and 3 seconds.

Note: The MDAs may be configured to report data bi-directionally.

Refer to section 5.6 for more details on remote reporting.

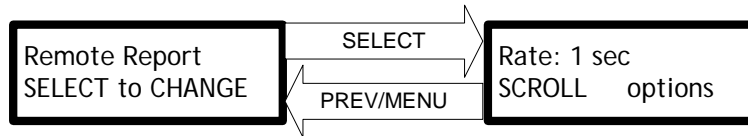

Figure 5-61: Remote Report Rate Configuration

5.5.2.12 SNMP IP Address

This display allows the MDA network manager's IP address to be configured. All SNMP traps will be directed to this address.

Refer to section **Error! Reference source not found.** for more details on SNMP trapping.

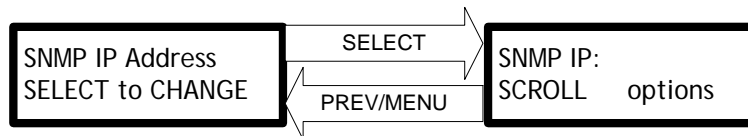

Figure 5-62: SNMP IP Address Configuration

5.5.2.13 SNMP Port

This display allows the MDA network manager's port number to be configured. All SNMP traps will be directed to this port number. This parameter may be configured between 1 and 65535.

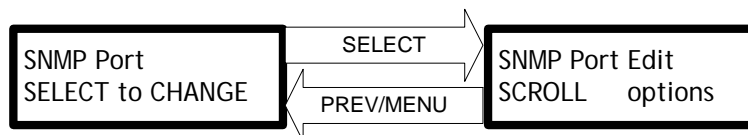

Figure 5-63: SNMP Port Configuration

5.5.2.14 Error Rate

The MDA will generate a trap when the rate of frame errors reaches the level specified by this parameter. This parameter may be configured between 1 and 44 frame errors per second.

Note: Black digital link rate is 44 frames per second.

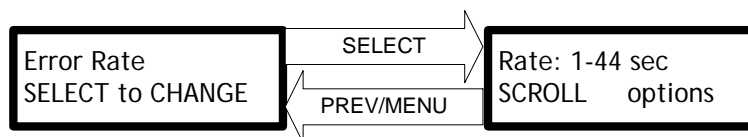

Figure 5-64: Error Rate Configuration

5.5.2.15 Error Count

The MDA will generate a trap when the number of frame errors reaches the count specified by this parameter.

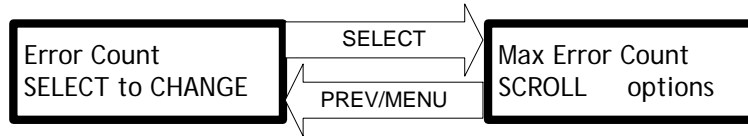

Figure 5-65: Error Count Configuration

5.5.2.16 Error Count Trap Severity

This display allows the severity level of the Error Count trap to be configured. The selection options available are Minor, Major, Critical, and Disabled. When configured to Disabled, no Error Count traps will be generated.

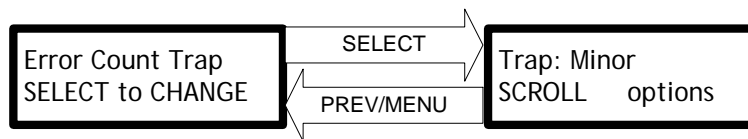

Figure 5-66: Error Count Trap Configuration

5.5.2.17 Error Rate Trap

This display allows the severity level of the Error Rate trap to be configured. The selection options available are Minor, Major, Critical, and Disabled. When configured to Disabled, no Error Rate traps will be generated.

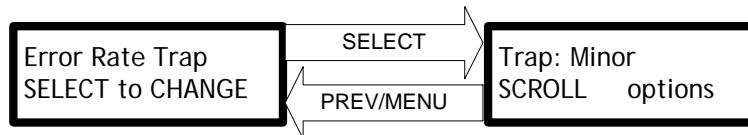

Figure 5-67: Error Rate Trap Configuration

5.5.2.18 UDLT Trap Severity

This display allows the severity level of the UDLT trap to be configured. The selection options available are Minor, Major, Critical, and Disabled. When configured to Disabled, no Error Count traps will be generated. The severity level is configurable on a per UDLT interface basis. Individual traps setting are available for each UDLT interface.

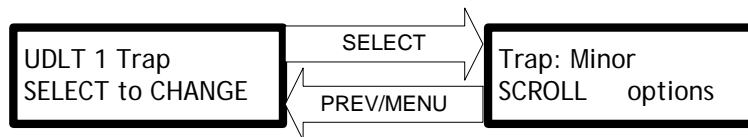

Figure 5-68: UDLT 1 Trap Configuration

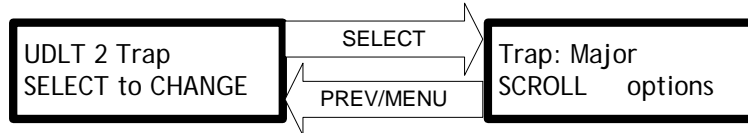

Figure 5-69: UDLT 2 Trap Configuration

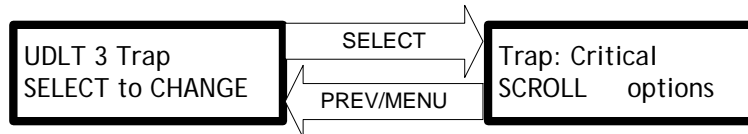

Figure 5-70: UDLT 3 Trap Configuration

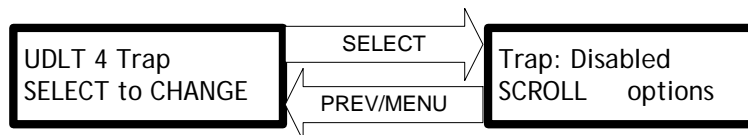

Figure 5-71: UDLT 4 Trap Configuration

5.5.2.19 Fail Duration

Refer to section **Error! Reference source not found.** for details on this parameter.

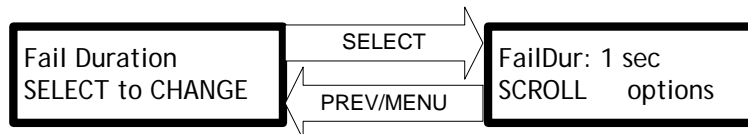

Figure 5-72: Fail Duration Configuration

5.5.2.20 Fade Duration

Refer to section **Error! Reference source not found.** for details on this parameter.

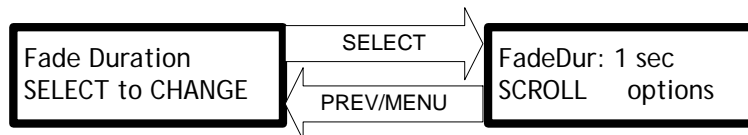

Figure 5-73: Fade Duration Configuration

5.5.2.21 Chatter Duration

Refer to section **Error! Reference source not found.** for details on this parameter.

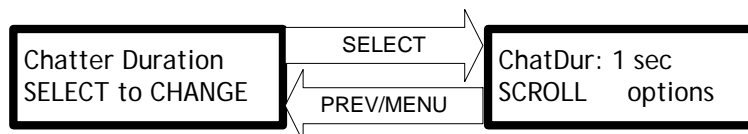

Figure 5-74: Chatter Duration Configuration

5.5.3 Modifying the MDA Ethernet Addresses

In the event the user would like to reconfigure the 100 Mbit or the 10 Mbit Ethernet addresses, this is possible from the front panel. Once the user has arrived at the 100 Mbps/10 Mbps Edit screens, the current IP address is displayed. The MDA will place a cursor in the first digit position of the display and will be denoted with brackets []. While the cursor is in this position, pressing the PREV/MENU button will increment the digit and pressing the SELECT button will decrement the digit. Selecting the SCROLL button advances the cursor to the next digit. Each digit of the IP address can be adjusted in the same manner. When the last digit has been modified to the desired value, continue by selecting the SCROLL button, at which time the complete modified address will be displayed and the bottom line of the display instructs the user to press SELECT to SAVE. Pressing the SELECT button saves the new IP address and the modifications will take place the next power up of the MDA. This modification process is the same for the 100 Mb and 10 Mb ports on the MDA. The same process is used to set or change the SNMP IP Address which is the IP address of the Network Manager.

5.6 Remote Status Information

There are several displays in this section, which are displayed to the user in successive depressions of the SCROLL key. Exiting this “subsystem” is achieved by pressing the PREV MENU key and the user is returned to the Remote Status Display Menu. The displays contained in the Remote Status reporting subsystem are outlined below in the order in which they appear: The remote status for each item below is valid only when the MDAs are operated in either 4-Phone or 4-Trunk (non-fiber) mode and the link between the two units is up. Also Remote Reporting must be enabled on the distant MDA using the System Parm Edit menus.

5.6.1 Remote MDA UDLT Remote Status Display

This display shows the current status of UDLT interfaces connected to the remote MDA. The remote UDLT status is identical as provided locally at the Statistics Information screen described in section 5.3.2.1.

```

UDLT: 1 2 3 4
      v ^ v v
  
```

Figure 5-75: Remote MDA UDLT Status Display (port up or down)

```

UDLT: 1 2 3 4
VD    v ^ v v
  
```

Figure 5-76: Remote MDA UDLT Valid Data Ports

```

UDLT: 1 2 3 4
LHC   v ^ v v
  
```

Figure 5-77: Remote MDA UDLT Long Haul Communications

5.6.2 Remote MDA BSP Part Number and Revision Display

This display shows the part number and the current revision of the Motorola 860 Power PC processor's Board Support Package (BSP).

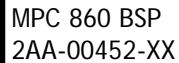

```
MPC 860 BSP
2AA-00452-XX
```

Figure 5-78: Remote MDA Board Support Package Part Number and Revision Display

5.6.3 Remote MDA Application Part Number and Revision Display

This display shows the part number and the current revision of the Motorola 860 Power PC processor's Application code.

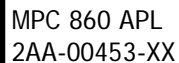

```
MPC 860 APL
2AA-00453-XX
```

Figure 5-79: Remote MDA Application Code Segment Part Number and Revision Display

5.6.4 Remote MDA Multilink PPP Application Part Number and Revision Display

This display shows the part number and the current revision of the Multilink Point to Point Protocol software running on the Motorola 860 Power PC processor.

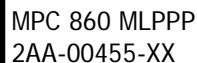

```
MPC 860 MLPPP
2AA-00455-XX
```

Figure 5-80: Remote MDA Application Code Segment Part Number and Revision Display

5.6.5 Remote MDA DSP Part Number and Revision Display

This display shows the part number and the current revision of the firmware currently operating in the DSP. This part number is extracted from the DSP during operation.

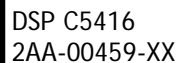

```
DSP C5416
2AA-00459-XX
```

Figure 5-81: Remote MDA Digital Signal Processor Part Number and Revision Display

5.6.6 Remote MDA FPGA Part Number Display

This display shows the part number and the current revision of the firmware currently loaded in the Fixed Programmable Gate Array. This part number is extracted from the FPGA during operation.

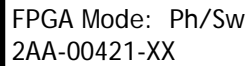

```
FPGA Mode: Ph/Sw
2AA-00421-XX
```

Figure 5-82: Remote MDA FPGA Part Number Display

5.6.7 Remote MDA CPLD Part Number Display

This display shows the part number and the current revision of the firmware currently loaded in the Complex Programmable Logic Device. This part number is extracted from the CPLD during operation.

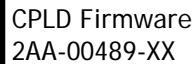

```
CPLD Firmware
2AA-00489-XX
```

Figure 5-83: Remote MDA CPLD Part Number Display

5.6.8 Remote MDA Internal Temperature Display

This display shows the current temperature inside the remote MDA unit expressed in degrees Celsius.



```
Temperature
40' C
```

Figure 5-84: Remote MDA Internal Temperature Display

5.6.9 Remote MDA Serial Number Display

This display shows the Serial number of the remote MDA unit programmed from the factory

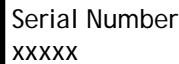

```
Serial Number
xxxxx
```

Figure 5-85: Remote MDA Serial Number Display

5.6.10 Remote MDA 100 Mbit Ethernet Address Display

This display shows the current IP address of the remote MDA's 100 Mb Fast Ethernet port. This IP can be changed from the front panel and is covered in the System Parameter Edit section of this manual.

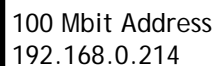

```
100 Mbit Address
192.168.0.214
```

Figure 5-86: Remote MDA 100 Mbit Ethernet Address Display

5.6.11 Remote MDA 10 Mbit Ethernet Address Display

This display shows the current IP address of the remote MDA's 10-Base T Ethernet port. This IP can be changed from the front panel and is covered in the System Parameter Edit section of this manual.

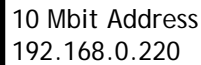

10 Mbit Address
192.168.0.220

Figure 5-87: Remote MDA 10 Mbit Ethernet Address Display

5.6.12 Remote MDA Operating Mode

This display shows the operating configuration of the remote MDA.

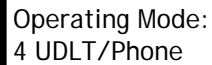

Operating Mode:
4 UDLT/Phone

Figure 5-88: Remote MDA Operating Mode

5.6.13 Remote MDA MIL188 ReSync

This display shows the resync count of the remote MDA

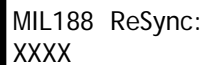

MIL188 ReSync:
XXXX

Figure 5-89: Remote MDA ReSync Count

5.6.14 Remote MDA MIL188 ReCenter

This display shows the re-center count of the remote MDA

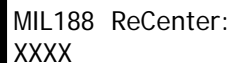

MIL188 ReCenter:
XXXX

Figure 5-90: Remote MDA ReCenter Count

5.7 Detailed Menu

Figure 5-91, Figure 5-92 and Figure 5-93 provide detailed front panel navigation menus for MDA status retrieval and configuration setup.



Figure 5-91: Detailed MDA Menus – Statistics Info and System Config

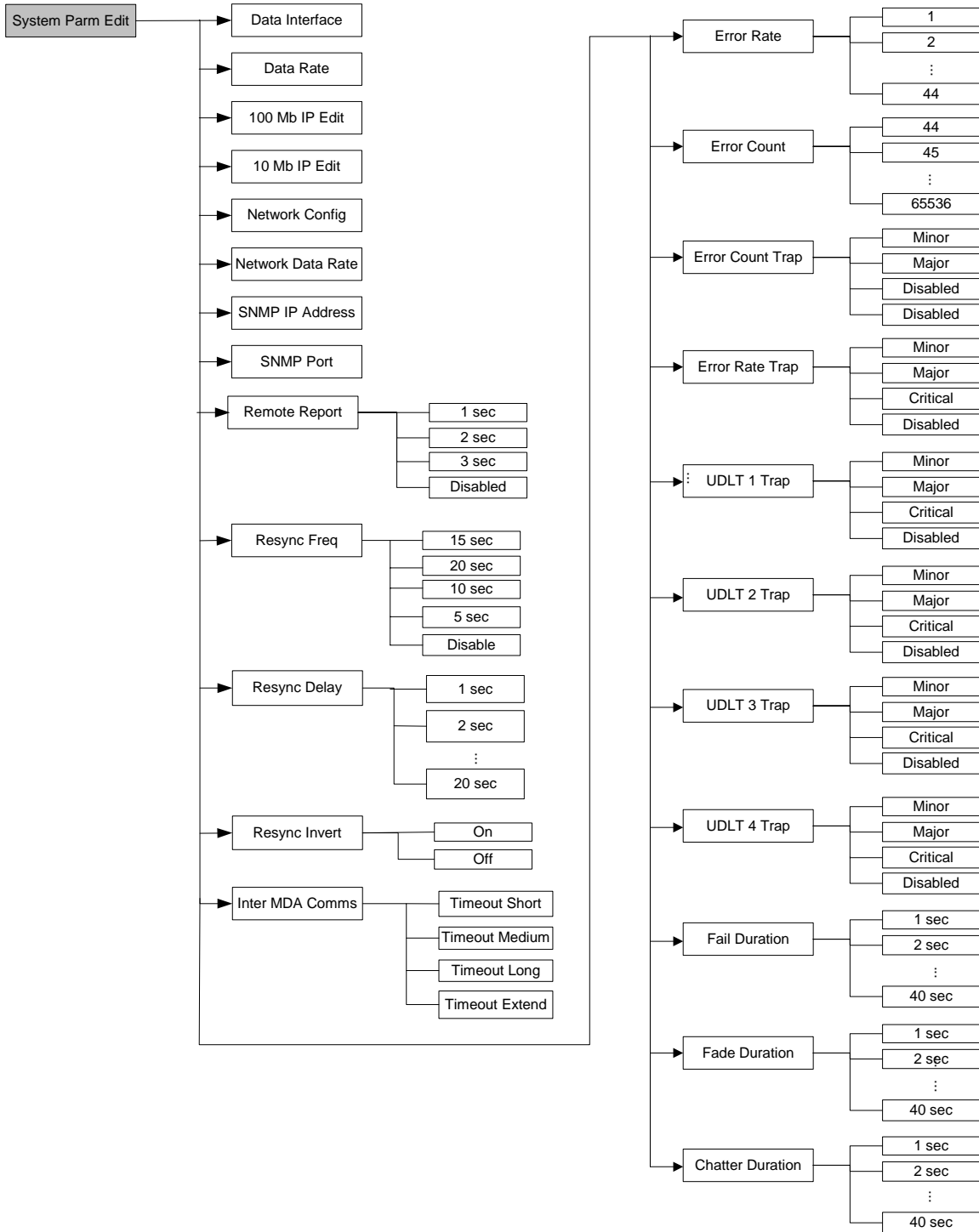

Figure 5-92: Detailed MDA Menus – System Parm Edit

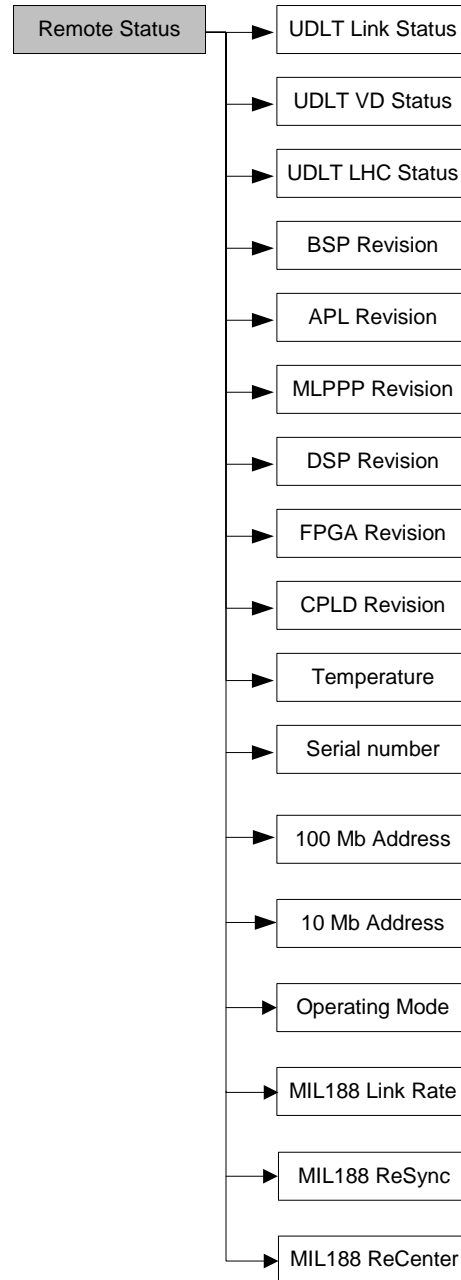

Figure 5-93: Detailed MDA Menus – Remote Status

6 MDA Crypto Resync Capability

The crypto resync signal can be used when there are end-to-end link synchronization issues. The software and firmware for this revision provide both an RS232 and RS422 level outputs using connectors,

MDA 1: J3

MDA 2: J8

Both resync signals are active when an out-of-sync condition is detected by the MDA. The resynchronization process toggles the resync line with a 1 second on followed by an off time configurable through the MDA front panel.

6.1 “Single Ended” Resync

The RS-232 level RESYNC signal is typically used for KIV-7 cryptographic devices that require a “single ended” resync signal.

Table 6-1 describes the pins associated with “Single Ended” resync.

	Connector	Pin	Description
MDA 1	J3	13	RESYNC-P (positive going “single ended” resync signal)
MDA 1	J3	3	Signal Ground
MDA 2	J8	13	RESYNC-P (positive going “single ended” resync signal)
MDA 2	J8	3	Signal Ground

Table 6-1: “Single Ended” Resync Pin Definitions

6.2 “Differential” Resync

The RS-422 level RESYNC signal is typically used for older KG-84 type cryptographic devices that require a differential resync signal. Please note, the differential resync signal uses solid-state electronics and is not a contact closure (relay) type resync signal. Utilizing the differential resync signal in a manner consistent with a contact closure type application could damage the MDA or crypto device and will void the MDA warranty. Consult your crypto user's manual for the correct signal level prior to connecting the signal.

	Connector	Pin	Description
MDA 1	J3	43	RESYNC-P (positive going resync signal)
MDA 1	J3	36	RESYNC-N (negative going resync signal)
MDA 2	J8	43	RESYNC-P (positive going resync signal)
MDA 2	J8	36	RESYNC-N (negative going resync signal)

Table 6-2: “Differential” Resync Pin Definitions

6.3 Crypto Resync/Link Configuration Capability

The installer has the flexibility to configure the characteristics of the software surrounding link management and assertion/de-assertion of the crypto resync logic. The following settings work in conjunction to perform the MDA Link Management function:

- 1) Resync Delay : Initial time delay after detection of link failure by the software before asserting the crypto resync logic. This setting is programmable from 1 to 20 seconds
- 2) Resync Frequency: Frequency of assertions of the crypto resync logic after the initial delay. This setting is programmable for 5 seconds, 10 seconds, 15 seconds and 20 seconds. The installer can also disable the resync logic by selecting "disable".
- 3) Resync Invert: This database element describes the polarity of the resynchronization signal.
- 4) Inter-MDA Comms: Inter MDA Communications timeout. This setting is programmable for a short, medium, long and extended setting. On some of the slower links the system can be configured for a more lenient tolerance, but for most circuits the short setting is sufficient.

NOTE: The Inter-MDA Communications timeout MUST be configured from the front panel whenever upgrading the software. Both MDA's must be set for the same Inter MDA timeout. Undesirable results will occur if this setting is different between a "master" and "slave" MDA. Additionally the Inter-MDA Comms timeout (short, medium, long or extended polling between MDAs) must be set to be longer than the Resync Delay value (a value of 1 to 20 seconds) to avoid link problems. The "short" setting equates to a value of 4-5 seconds, the "medium" setting equates to a value of 10-12 seconds, the "long" setting equates to a value of 20-22 seconds, and the "extended" setting equates to a value of 30-35 seconds. Table 6-3 provides valid settings for these user configurable parameters.

Inter-MDA Comms Settings	Valid Resync Delay Setting
Short 4-5	1-3
Medium 10-12	1-9
Long 20-22	1-19
Extended 30-35	1-20

Table 6-3: Valid Settings for User Configurable Crypto Resync/Link Configuration Parameters

6.4 Crypto Alarm for Black Digital Mode

The MDA-A provides an alarm output for each MDA when configured for Black Digital Subscriber or Black Digital Trunk mode. The alarm is active whenever the MDA's MIL188 link is in a failed state. The alarm output is a balanced RS422 signal; however, looping this logical alarm output back into the MDA, a relay contact closure output is provided by the MDA. Figure 6-1 below identifies the external wiring required to get the contact closure alarm output.

Note 1: Pins 50 and 21 provide a balanced RS422 alarm output. This logical alarm output is then used as a control signal to activate a relay on a Relay Adapter Board (2AA-02344-0000) internal to the MDA-A. Pins 50 and 21 must be externally connected to pins 31 and 2 per diagram below on J3 and J8 to provide the alarm relay drive that then provides the Relay Alarm contact closure output at pins 28 and 54.

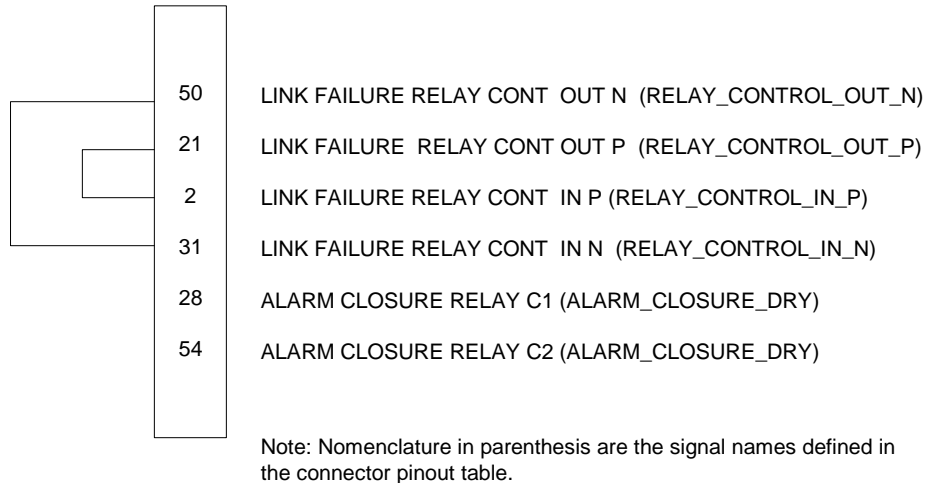

Figure 6-1: J3/J8 External Wiring for Alarm

6.5 Special Configuration Instructions for MDA Black Digital Parameters

The fade, failure, and chatter durations apply only to Black Digital mode (see Figure 9-92 for front panel setup). They are benign (not functional) in all other modes. The front panel parameter's configurations prevent the user from configuring unsupported durations.

Two basic combinations of fade and failure are supported by the MDA: fade duration equal to failure duration and fade duration less than failure duration. When the parameters are equal, the fade duration is ignored and the MDA operates as if the “fade” state did not exist. Otherwise, while the MDA is failing, it will enter a “fade” state from the time the fade duration is expired until the failure duration is expired (ignoring the possible recovery scenario).

Note: Typical configuration based on simulated failures in a lab environment (may not reflect real world environment).

Fade

The fade duration should be configured as the shortest possible duration of link failure that the user should be aware of. Ideally, this will be one second. If the link has high bit errors or frame loss then a higher duration of two to five seconds might be required. Anything greater probably indicates an unusable link.

Failure

The failure duration should be configured as the shortest possible duration of link failure that the switch should be aware of. Any value greater than twenty seconds will likely be truncated by the failure of the underlying protocol. Users desiring a faster indication of failure should use a number closer to the fade duration. For example, if the fade duration was one second, the failure duration should be from five to ten seconds. Longer durations may be desired if the user wishes to tolerate longer periods of timeout with the possibility of operating in more failure-prone links.

Chatter

The chatter duration should be configured as the shortest possible duration of link synchronization that indicates the link is usable again. Ideally, this value should be greater than the fade duration, to provide assurance that the link is fully recovered and ready for use. The longer the chatter, the less likely the link

will bounce up and down from the user's perspective after a fade or failure. However, if the user wishes to exit fades in a timely matter, the chatter duration should be configured as short as possible. A shorter chatter will allow the link to recover from fade in a shorter period of time. To prevent every fade from resulting in a failure, this value is required to be less than the difference between the fade and failure durations.

Relation to crypto re-sync

Crypto re-sync is initiated whenever the link has failed and the synchronization status bit has failed as well. If the crypto loses sync within a fade condition, the re-sync will not be initiated and the link must go through a failure condition. The crypto re-sync is closely tied to the chatter duration. A longer delay of the crypto re-sync will extend the chatter duration (in reality) because the cryptos must recover for the link to recover. Ideally, the crypto re-sync initial delay should be less than or equal to the chatter duration.

Example configurations:

Version 17 behavior:

Fade duration: 1 second

Failure duration: 1 second

Chatter duration: 1 second

Non-lossy link

Fade duration: 1 second

Failure duration: 10 seconds

Chatter duration: 3 seconds

Lossy link:

Fade duration: 3 seconds

Failure duration: 20 seconds

Chatter duration: 5 seconds

Very lossy link:

Fade duration: 5 seconds

Failure duration: 30 seconds

Chatter duration: 3 seconds

7 SNMP Trapping

The MDA supports trapping of events via SNMP when certain conditions occur and sending the trap an SNMP Manager. When a UDLT link state changes, a trap is sent. Each UDLT link has its own severity setting and each can be disabled independently. Also, traps are sent when the maximum rate of frame errors or the total number of frame errors allowed is exceeded. These will be reported to the SNMP Manager address configured in the SNMP IP Address field. All traps can have a severity level set to indicate the importance of the trap. Severity levels are minor, major, critical, or disabled if no trap should be sent, and can be set from the front panel's System Parm Edit menu.

8 Software Upgrade Instructions

These upgrade instructions are provided for reference only and for use by trained personnel who are familiar with the MDA and the load procedures. Prior to upgrade, the user must obtain some information from the MDA. The software or firmware of the MDA must be obtained as well as the IP address of the 100 Mb Ethernet port. This information can be obtained from the front panel Statistics Menu information screen of the MDA. The files will be upgraded using the File Transfer Protocol (FTP) facility to transfer the required file(s) to the MDA from a remote computer.

The MDA is programmed both by in circuit programming (a hardware programming pod attached to a PC) and by the system microprocessor during the initial stages of the system boot sequence. The CPLD is only programmable through in-circuit programming. If a CPLD change is required, the change must be made at Telecore's facility. The program files that are used by the microprocessor are stored in flash memory as binary files. The program files are loaded into flash memory by using the standard File Transfer Protocol (FTP) software that is available on a Personal Computer (PC) running the Windows NT, 2000, XP, 98 or 95 operating systems.

A Windows-based PC with a 10 Mbit or 10/100 Mbit Ethernet Interface is needed to connect the PC to the

MDA 1: J4 (10/100 Mbit)
MDA 2: J9 (10/100 Mbit)

when installing MDA software/firmware. Optionally, the MDA J4/J9 can be connected to an Ethernet LAN (Local Area Network) using a hub/switch with a standard CAT-5 Ethernet cable (the PC must be connected to the hub that is connected to the MDA).

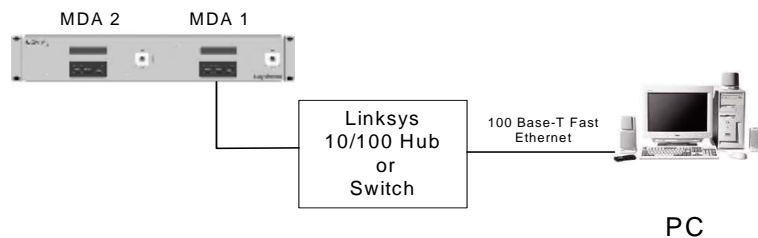

Figure 8-1: MDA Software Download Setup

8.1 Obtaining Files for Upgrade

Before starting, read the instructions for installing the software/firmware below. Obtain the files from Telecore's Website, Telecore configuration control, or other controlled source for file distribution. Copy all the files to a directory on the PC that will be used to connect to the MDA. Unzip the files if necessary using WINZIP. For this example, the files will be copied to the C: drive of the PC.

Prepare to download the files onto the MDA. These files consist of the following, where XXXX represents the latest version:

1. FPGA firmware, 2AA-00421-XXXX (mda.jbc)
2. FPGA Black Digital firmware, 2AA-00417-XXXX (mda_blk.jbc)
3. 860 Application, 2AA-00453-XXXX (mda.out)
4. MDA Configuration file, 2AA-00420-XXXX (config.mda)
5. 860 ML/PPP, 2AA-00455-XXXX (mdamlppp.out)
6. 860 BSP, 2AA-00452-XXXX (boot.bin)
7. DSP software, 2AA-00459-XXXX (mda.hex)
8. DSP black digital software, 2AA-00428-XXXX (mda_blk.hex)

8.2 Determining the MDA IP address and the BSP Version

The MDA's 100 Mb Ethernet address and the BSP revision can be retrieved on an operational unit by scrolling through the Statistics Menu (Run Time Status->Statistic Info). The Ethernet address needed is displayed under the heading "100 Mb Ethernet" and the BSP revision needed is displayed under the heading "BSP Revision".

During the procedures that follow, the current settings of the MDA will be lost. Before continuing with the installation, record the current configuration of the MDA software component so that it can be re-configured after the upgrade process is complete.

8.3 MDA BSP

Based on the BSP revision obtained in 8.2, the user may or may not need to upgrade the BSP. In some instances it will not be necessary to load an entire set of software/firmware. If a new BSP is required (determined by release), then the user must reload the entire set of software/firmware as described below. If a single or a subset of the remaining files (Software Application, DSP Application, and FPGA firmware) needs to be loaded, then the steps described in this section can be skipped. The following upgrade instructions assume an IP Address of 192.168.0.217. The end user would substitute the IP Address obtained in section 8.2.

At the PC, open a Command Window. In the command window, change to the directory where the files are located.

At the command prompt, type `ftp 192.168.0.217<return>`. (Substituting the IP address obtained in section 8.2)

You will see a request for a user name and a password. Simply press the return key until you see the FTP prompt. (You should now see the prompt, "FTP>".)

At the FTP prompt, type the following commands (where XX represents the desired (latest) revision):

```
FTP>bin <return>
FTP>put 2AA-00452-XX.bin boot.bin <return>
FTP>close<return>
FTP>quit <return>
```

You should now be back at the command prompt

Start a telnet connection from the PC command window command line by entering:

```
telnet 192.168.0.217. (Again substituting your IP address, you should see the prompt, "MDA>".)
```

To begin the programming of the BSP type the following at the MDA prompt:

```
MDA>progBoot
```

The MDA will begin the initial reprogram of the BSP. The cursor will stay at the end of the command line for a short time, then it will scroll flash erasing messages. This may take some time so wait a while before proceeding.

```
flashBootErase: Erasing block address = 0x8000000
.
flashBootErase: Erasing block address = 0x83f0000
flash programming complete
value=23=0x17
```

After the messages finish, the procedure is complete. Log out of the telnet connection by closing the window.

Turn the power to the MDA Off, wait a few seconds and turn the power to the MDA back On. Wait a few minutes for the MDA to recover.

The new BSP is now loaded on the MDA. The MDA LCD display will show, "APPLICATION CODE NEEDED".

Press scroll button to display the current IP Address.

8.4 MDA Application/DSP/MLPPP Software and FPGA Firmware

At the PC open a DOS window (Command Window).

At the DOS prompt type

ftp 192.168.0.217 <return>. (Substituting the IP address determined in section 8.2 or obtained at the end of section 8.3)

You will see a request for a user name and a password. Simply press the return key until you see the FTP prompt. (You should now see a prompt FTP>)

At the FTP prompt type the following commands, (where XX and/or XXXX represents the desired (latest) revision):

Load Application Software

```
FTP>cd /apl <return>
FTP>bin <return>
FTP>put 2AA-00453-XXXX.out mda.out <return>
```

Load Software Configuration File (Only needs to be loaded if BSP is loaded)

```
FTP>put 2AA-00420-XX.mda config.mda <return>
```

Load MLPP Software

```
FTP>put 2AA-00455-XXXX.out mdamlpp.out <return>
```

Load FPGA Files

```
FTP>cd ..
FTP>cd /usr <return>
FTP>put 2AA-00417-XXXX.jbc mda_blk.jbc <return>
FTP>put 2AA-00421-XXXX.jbc mda.jbc <return>
```

Load DSP Software

```
FTP>put 2AA-00428-XXXX.hex mda_blk.hex <return>
FTP>put 2AA-00459-XX.hex mda.hex <return>
FTP>close <return>
FTP>quit <return>
```

You should now be back at the DOS prompt.

At the PC, open a TELNET session into the MDA and enter the following command at the console:

```
telnet 192.168.0.217 Again substituting your IP address. (You should see the prompt, "MDA>".)
```

Execute the following Command at the user prompt. The following command does NOT need to be executed if the BSP is loaded in section 8.3.

```
MDA> rm "/usr/system.dbf"<return>
```

Turn the power to the MDA Off, wait a few seconds and turn the power to the MDA back On. Wait a few minutes for the MDA to recover. The new versions of the MDA firmware will be used to reprogram the MDA during the power up process of the MDA. *NOTE: The status of the firmware reprogramming process is displayed on the LCD display.* The new software and firmware are now loaded on the MDA.

Configure the MDA for desired operation. Be sure to check/configure the Inter-MDA Comms timeout for the desired circuit. It is important that both ends of the circuit are configured for the same timeout.

8.4.1 Special Configuration Instructions for MDA Application Software Upgrade

8.4.1.1 Crypto Resync Configuration

When loading 2AA-00453-1600 (and subsequent versions) on to an MDA connected to an existing circuit, it is imperative that the installer understands that the crypto resync settings must be configured appropriately for the circuit in which the MDA is to be connected. Following the upgrade procedure previously described, the crypto resync capability of the MDA will be initialized to the following settings:

- Resync Frequency: 10 seconds
- Resync Delay: 3 seconds
- Crypto Invert: No

Resync Frequency – This setting is the time between assertions of the resync signal after the initial Resync Delay. This setting also provides for disabling of the Resync logic in the MDA.

Resync Delay – This setting is the time between physical link failure and the first assertion of the resync signal.

Crypto Invert – This setting inverts the asserted and de-asserted outputs of the Resync logic.

8.4.1.2 Inter-MDA Communications Configuration

When loading 2AA-00453-1600 (and subsequent versions) on to an MDA connected to an existing circuit, it is imperative that the installer understands that the period of time between the sync loss detection and software link failure detection is now configurable. The MDA provides four time periods that are selectable from the front panel of the MDA.

Short:	Inter MDA link fails in approximately 4-5 seconds.
Medium:	Inter MDA link fails in approximately 10-12 seconds.
Long:	Inter MDA link fails in approximately 20-22 seconds.
Extended:	Inter MDA link fails in approximately 30-35 seconds.

When the Inter MDA link fails, communications on the UDLT channels are stopped and not restarted until the link recovers. This failure is what causes the phones to appear unplugged to the switch.

9 Connector Signals

9.1 J1 and J2

The J1 and J2 power connectors provide AC power to an internally fused 48V power supply. The fuse is rated at 3 Amps. It is **NOT** field replaceable. The 48V supply has overload and short circuit protection. In an overload condition, the output shuts down. The output will recover when the overload condition is removed. In a short circuit condition, the output shuts down, disabling power to the MDA. The power cord for the MDA-A is Telecore P/N 2AA-02357-0000.

9.2 J3, J8 - RS-232 Async and Synchronous Interface, Electrical T1/E1, MIL-188-114, Resync and Alarm Interface

The connectors J3 and J8 provide access to the RS-232 asynchronous and synchronous interfaces, the 16 kbps synchronous data port and the 9.6 kbps asynchronous data port. Only one of these interfaces (Synchronous or Asynchronous) is supported at a time. The data ports will provide support of the legacy BRAVO II mode of operation of the DTA/DPA. This is the same capability as the data ports, port A and B, on the Raytheon DTA/DPA. An electrical T1/E1 interface is also provided on this connector. The T1/E1 electrical interface is a future additional interface option for use with the MDA. These connectors also contain Crypto Resync signals and Alarms signals.

The connectors also provide access to the MDA MIL-188-114 network interface and some spare RS-232 interfaces. Most of the MIL-188 signals are balanced and are capable of operating at cable lengths up to 60 meters. However, some signals are unbalanced and, if used, limit the cable distance to less than 15 meters. Refer to Table 9-1 for pin-out information.

Pin Out Of The 55 Pin Circular Bulkhead Receptacles J3 And J8 RS232, RS422, MIL-188-114, Resync And Alarm Interface			
J3, J8 Pin	Signal Name	Direction I/O	Description
4	CHASSIS	NA	FRAME GND
10	RS232_SPARE1_IN	I	SPARE RS232 INPUT
17	RS232_SPARE2_IN	I	SPARE RS232 INPUT
25	CHASSIS	NA	FRAME GND
32	RS232_DPORTA_TXCLK	O	RS232 DPORTA TXCLK
40	RS232_DPORTA_RXCLK	O	RS232 DPORTA RXCLK
47	GND	NA	DIGITAL GND
1	CHASSIS	NA	FRAME GND
5	RS232_SPARE_IN	I	RS232 SPARE IN
11	RS232_DPORTA_RTS	I	RS232 RTS
18	CHASSIS	NA	FRAME GND
33	T1/E1_RX_N	I	T1/E1 RX DATA NEGATIVE
41	T1/E1_RX_P	I	T1/E1 RX DATA POSITIVE
48	CHASSIS	NA	FRAME GND
53	RS232_DPORTA_TXD	I	RS232 TX DATA
6	RS232_SPARE_IN	I	RS232 SPARE IN
12	CHASSIS	NA	FRAME GND
19	RS232_DPORTA_CTS	O	RS232 CTS
26	RS232_DPORTA_RXD	O	RS232 RX DATA
34	GND	NA	DIGITAL GND

42	RS232_SPARE3_IN	I	SPARE RS232 INPUT
49	RS232_SPARE3_OUT	O	USED TO DEASSERT RTS
13	RS232_SPARE4_OUT	O	RS232 CRYPTO RESYNC-P
20	CHASSIS	NA	FRAME GND
27	T1/E1_TX_N	O	T1/E1 TX DATA NEGATIVE
35	T1/E1_TX_P	O	T1/E1 TX DATA POSITIVE
2	RELAY_CONTROL_IN_P	I	LINK FAILURE RELAY CONT P
31	RELAY_CONTROL_IN_N	I	LINK FAILURE RELAY CONT N
28	ALARM_CLOSURE_DRY	O	ALARM CLOSURE RELAY
54	ALARM_CLOSURE_DRY	O	ALARM CLOSURE RELAY
9	CHASSIS	NA	FRAME GND
16	MIL_188_TX_CLK_N	O	MIL-188-114 TX DATA CLK N
24	MIL_188_TX_CLK_P	O	MIL-188-114 TX DATA CLK P
39	CHASSIS	NA	FRAME GND
46	MIL_188_TX_DATA_N	O	MIL-188-114 TX DATA N
52	MIL_188_TX_DATA_P	O	MIL-188-114 TX DATA P
3	GND	NA	DIGITAL GND
8	CHASSIS	NA	FRAME GND
15	MIL_188_RX_CLK_N	I	MIL-188-114 RX DATA CLK N
23	MIL_188_RX_CLK_P	I	MIL-188-114 RX DATA CLK P
38	RS422_SPARE_IN_N	I	RS422 SPARE INPUT N
45	RS422_SPARE_IN_P	I	RS422 SPARE IN PUT P
51	CHASSIS	NA	FRAME GND
55	MIL_188_RX_DATA_N	I	MIL-188-114 RX DATA N
7	MIL_188_RX_DATA_P	I	MIL-188-114 RX DATA P
14	CHASSIS	NA	FRAME GND
22	RS422_CLK_OUT_N	O	RS422 CLK OUT NEGATIVE
30	RS422_CLK_OUT_P	O	RS422 CLK OUT POSITIVE
37	GND	NA	DIGITAL GND
44	RS232_SPARE4_IN	I	SPARE RS232 INPUT
50	RELAY_CONTROL_OUT_N	O	LINK FAILURE RELAY CONT N
21	RELAY_CONTROL_OUT_P	O	LINK FAILURE RELAY CONT P
29	CHASSIS	NA	FRAME GND
36	RS422_SPARE1_OUT_N	O	RS422 CRYPTO RESYNC N
43	RS422_SPARE1_OUT_P	O	RS422 CRYPTO RESYNC P

Table 9-1: Connector J3, J8 - RS-232 Async/Sync, T1/E1, MIL-188-114 Interface and Alarm Closure

9.3 J4, J5, J9 and J10 - UDLT and Ethernet Interfaces

The J4, J5, J9 and J10 connectors provide access to the MDA-A 10/100BaseT, 10BaseT and UDLT interfaces.

Please note, when used in Bravo modes, UDLT1 is the primary UDLT interface and UDLT 2 is the secondary UDLT interface. When the MDA is used at the phone end, 48V DC will be supplied over the twisted wire pair to power the phones. At the switch end, the MDA disconnects its 48VDC from the line so there is no contention with the switch. The MDA does not use the 48VDC when it's used at the switch end. Tables 9-2 and 9-3 detail the pin-outs of the UDLT and Ethernet interfaces.

Pin Out Of The 22 Pin Circular Bulkhead Receptacles J4 And J9 10/100BaseT Ethernet, UDLT 1, UDLT 2			
J4, J9 Pin	Signal Name	Direction I/O	Description
4	TX +	O	TRANSMIT DATA POSITIVE
3	TX -	O	TRANSMIT DATA NEGATIVE
2	RX +	I	RECEIVE DATA POSITIVE
1	TERMINATION	I	TERMINATION
14	TERMINATION	I	TERMINATION
13	RX -	I	RECEIVE DATA NEGATIVE
12	TERMINATION	I	TERMINATION
11	TERMINATION	I	TERMINATION
21	DRAIN	NA	SHIELD
6	UDLT1_P	I/O	UDLT 1 POSITIVE
17	UDLT1_N	I/O	UDLT 1 NEGATIVE
5	DRAIN	NA	SHIELD
9	UDLT2_P	I/O	UDLT 2 POSITIVE
19	UDLT2_N	I/O	UDLT 2 NEGATIVE
10	DRAIN	NA	SHIELD
7	NC		
8	NC		
15	NC		
16	NC		
18	NC		
20	NC		
22	NC		

Table 9-2 : Connector J4, J9 – UDLT channels 1 & 2, 10/100 BaseT Ethernet Ports

Pin Out Of The 22 Pin Circular Bulkhead Receptacles J5 And J10 10 BaseT Ethernet, UDLT 3, UDLT 4			
J5, J10 Pin	Signal Name	Direction I/O	Description
4	TX +	O	TRANSMIT DATA POSITIVE
3	TX -	O	TRANSMIT DATA NEGATIVE
2	RX +	I	RECEIVE DATA POSITIVE
1	TERMINATION	I	TERMINATION
14	TERMINATION	I	TERMINATION
13	RX -	I	RECEIVE DATA NEGATIVE
12	TERMINATION	I	TERMINATION
11	TERMINATION	I	TERMINATION
21	DRAIN	NA	SHIELD
6	UDLT3_P	I/O	UDLT 3 POSITIVE
17	UDLT3_N	I/O	UDLT 3 NEGATIVE
5	DRAIN	NA	SHIELD
9	UDLT4_P	I/O	UDLT 4 POSITIVE
19	UDLT4_N	I/O	UDLT 4 NEGATIVE

10	DRAIN	NA	SHIELD
7	NC		
8	NC		
15	NC		
16	NC		
18	NC		
20	NC		
22	NC		

Table 9-3: Connector J5, J10 – UDLT channels 3 & 4, 10 BaseT Ethernet Ports

9.4 Transmit/Receive Fiber Optic Interface

MDA 1: J6 (RX), J7 (TX)

MDA 2: J11 (RX), J12 (TX)

These connectors are a ST type connection and are capable of reliably operating at fiber distances up to 4k meters using multimode fiber optic cable with a core/cladding size of 62.5/125 microns. This interface operates at a wavelength of 1310 nm, and has a link power budget of 10dB.

10 Terms/Definitions

AC	Alternating current
Alarm	An operational state (OK, MINOR, MAJOR, CATASTROPHIC)
CPLD	Complex Programmable Logic Device
CTS	Clear To Send
DSS	Digital Small Switch (Raytheon)
FPGA	Fixed Programmable Gate Array
GUI	Graphical User Interface
HMI	Human Machine Interface
I/O board	DSS interface board (e.g. T1, STI, STU-III/R)
IP	Internet Protocol
KIV-7	Embeddable KG-84 communications security (COMSEC) module
KPI	KG Phone Interface
KTI	KG Trunk Interface
LAN	Local Area Network
LBT	Low Bandwidth Trunk
LCD	Liquid Crystal Display
MDA-A	Multifunction Digital Adapter - Aircraft
MDA	Multifunction Digital Adapter
MIB	Management Information Block
ML	Multilink
NMS	Network Management System
P/N	Part Number
PPP	Point-to-point Protocol
PROM	Programmable Read Only Memory
R/C	Re-center
REM	Remote
RMA	Return Materials Authorization
R/S	Re-synchronize
RTS	Request To Send
SA	Local Site Admin that has local control over administration duties
SAL	Security Access Level
SDS	Secure Digital Switch (Raytheon)
Site	A place where DSS and/or LCC systems are installed
Standby	The DSS calls processor and matrix currently backing up the master
SNMP	Simple Network Management Protocol
STI	Summing Telephone Interface
STO	Special Technical Operations: an acronym for a government organization
STU	Secure Telephone Unit
S/W	Software
TCP	Transmission Control Protocol
UDLT	Universal Digital Loop Transceiver
VME	Versa Module Eurocard
VxWorks	3 rd party operating system
WAN	Wide Area Network

11 Warranty Terms and Conditions

Telecore, Inc. provides a manufacturer's warranty that for a period of one year commencing on date of shipment: Goods are and will be free from defects in design, material, and workmanship; will conform to and perform in accordance with the Specifications, if any; that it will convey good and valid title to all Goods; and that all Goods are being provided free and clear of any and all liens and encumbrances. This warranty will survive inspection, acceptance, and payment. This warranty shall be null and void in the event the Buyer or any third party attempts repair of the Goods without Telecore, Inc. advanced written authorization, or in the event the Goods are misused, including termination of non-compliant third party equipment on Telecore's interfaces, or damaged by Buyer, or shipped to any country other than that originally specified in Buyer's Purchase Order. Goods not meeting this warranty will be promptly repaired or replaced, at Telecore's option, upon return to Telecore's facility, freight prepaid; provided, however, that Buyer has first obtained a return materials authorization number ("**RMA Number**") from Telecore authorizing such return. An RMA number may be requested from Telecore's website at www.telecore.com. The RMA Number shall be placed on the exterior packaging of all returns.

THE FOREGOING WARRANTY IS IN LIEU OF ALL OTHER WARRANTIES, EXPRESS OR IMPLIED, INCLUDING, BUT NOT LIMITED TO, ANY IMPLIED WARRANTIES OF TITLE, MERCHANTABILITY, OR FITNESS FOR A PARTICULAR PURPOSE HOWSOEVER ARISING.

11.1 Shipping Return Address

Equipment will be shipped to the following Supplier address as directed by the Supplier's Customer Service Department at the time the RMA number is assigned:

ADDRESS:

Telecore Inc
1800 North Glenville Dr.
Suite 116
Richardson, TX 75081-1953
ATTENTION: Customer Service